

1<sup>st</sup> EDITION, --/--/----

Revision nr. 0,  
--/--/--

# **ESCAPE 214**

**DJLV**



MANUFACTURER : LH - LAMANNA HELICOPTER srl

MODEL : **ESCAPE**

ENGINE : **ROTAX 915 is A**

SERIAL NUMBER: \_\_\_\_\_

YEAR OF CONSTRUCTION: \_\_\_\_\_

TYPE CERTIFICATE NR:

LAMANNA  
HELICOPTER

*This Handbook must be carried in the aircraft at all times. Operation of the aircraft must be in compliance with the information and limitations herein.*

Intentionally blank

**REVISIONS REGISTER**

Each Revision of this Manual must be registered in the chart below.

New texts or modifies will be indicated by a vertical black bar on the left margin.

**REVISIONS REGISTER**

<b>REVISION Nr.</b>	<b>SECTION</b>	<b>PAGE</b>	<b>DATE</b>

## GENERAL

This pilot's operating handbook is designed as a guide for the safe operations of the ESCAPE helicopter during normal, abnormal and emergency conditions.

The responsibility for the safe and efficient conduct of the flight rests with the pilot; this include remaining within the limitations outlined in this manual, instrument markings and placards.

It is pilot's responsibility to be familiar with the contents of this manual and that the helicopter is in perfect condition for a safe flight.

The information provided herein complies with the certification requirements DULV "LTF-ULH NfL 2-460-19".

This publication contains information proprietary to LAMANNA HELICOPTER. Reproduction and/or resale of the information or illustrations contained herein is not permitted without the written approval of LAMANNA HELICOPTER. Additional copies of this publication and/or change service may be obtained from:

LAMANNA HELICOPTER s.r.l.  
Via Bacchiglione 1,  
36033 Isola Vicentina (VI), Italia  
Tel: +(39) 0444 702884  
e-mail: [admin@lamannahelicopter.com](mailto:admin@lamannahelicopter.com)

**TABLE OF CONTENTS**

<b>1</b>	<b>SECTION 1- DESCRIPTIVE DATA .....</b>	<b>10</b>
<b>2</b>	<b>SECTION 2 – LIMITATIONS .....</b>	<b>56</b>
<b>3</b>	<b>SECTION 3 – NORMAL PROCEDURES.....</b>	<b>71</b>
<b>4</b>	<b>SECTION 4 – EMERGENCY PROCEDURES .....</b>	<b>91</b>
<b>5</b>	<b>SECTION 5 – PERFORMANCE .....</b>	<b>113</b>
<b>6</b>	<b>SECTION 6 – WEIGHT AND BALANCE .....</b>	<b>124</b>
<b>7</b>	<b>SECTION 7 – USE AND MAINTENANCE .....</b>	<b>133</b>

**GENERAL CONTENTS**

**1 SECTION 1- DESCRIPTIVE DATA ..... 10**

1.1 ABBREVIATIONS AND DEFINITIONS ..... 10

**1.1.1 CONVERSION TABLES ..... 13**

1.2 GENERAL DESCRIPTION..... 14

1.3 MAIN ROTOR SYSTEM ..... 15

1.4 TAIL ROTOR SYSTEM..... 16

1.5 DRIVE SYSTEM..... 17

1.6 FLIGHT CONTROLS ..... 19

1.7 CONTROL FRICTION..... 23

1.8 COCKPIT LAYOUT AND ON-BOARD EQUIPMENT ..... 24

1.9 COCKPIT INSTRUMENTS ..... 25

**1.9.1 ADVISORY LIGHTS PANEL ..... 26**

**1.9.2 ECLIPSE NG – ELECTRONIC FLIGHT INSTRUMENT ..... 27**

**1.9.3 VHF RADIO ..... 29**

**1.9.4 TRANSPONDER ..... 30**

**1.9.5 ROTOR/ENGINE TACHOMETER ..... 30**

**1.9.6 ANEMOMETER..... 31**

**1.9.7 ALTIMETER ..... 31**

**1.9.8 VERTICAL CARD COMPASS ..... 31**

**1.9.9 ADDITIONAL USB SOCKETS ..... 32**

1.10 ENGINE ..... 33

1.11 GOVERNOR..... 36

1.12 CLUTCH ..... 38

1.13 FUEL SYSTEM ..... 40

1.14 ELECTRICAL SYSTEM..... 43

1.15 COOLANT SYSTEM ..... 44

1.16 OIL SYSTEM ..... 45

1.17 FRAME AND CABIN ..... 46

1.18 LANDING GEAR..... 47

1.19 CIRCUIT BREAKER PANEL ..... 48

1.20 HEAD PANEL ..... 49

1.21 ALL-ON PANEL..... 50

**1.21.1ENGINE KEY SELECTOR..... 50**

**1.21.2ALL-ON PANEL SWITCHES ..... 51**

---

1.22	SEATS, BAGGAGES AND BALLAST .....	52
1.23	OIL AND FLUID.....	53
1.24	STANDARD EQUIPMENT CHARCTERISTICS .....	54
<b>2</b>	<b>SECTION 2 – LIMITATIONS .....</b>	<b>56</b>
2.1	FLIGHT AND MANEUVER LIMITATIONS.....	56
2.2	COLOR CODE FOR INSTRUMENT MARKINGS .....	56
2.3	SPEED LIMITS .....	57
2.4	ROTOR SPEED LIMITS .....	58
2.5	ENGINE LIMITATIONS.....	59
2.5.1	STARTER UNIT CYCLE LIMITATION .....	59
2.6	ENGINE INSTRUMENTS INDICATIONS .....	60
2.7	GENERAL OPERATING TEMPERATURE LIMIT .....	61
2.8	TYPE OF FUEL .....	62
2.9	TRANSMISSION LIMITS.....	63
2.10	WEIGHT LIMITS .....	64
2.11	CENTER OF GRAVITY (CG) LIMITS .....	65
2.12	FUEL LIMITATIONS.....	66
2.13	PLACARDS.....	67
2.14	TELATEMP (TEMPERATURE RECORDING LABELS).....	68
2.15	SAFE LOAD FACTOR .....	69
<b>3</b>	<b>SECTION 3 – NORMAL PROCEDURES.....</b>	<b>71</b>
3.1	EXTERNAL CHECKS .....	71
3.2	PRE-FLIGHT CHECKS.....	72
3.3	CHECK LIST .....	77
3.4	ALTERNATIVE ENGINE START .....	83
3.5	TAKE-OFF PROCEDURE.....	84
3.6	APPROACH AND LANDING .....	85
3.7	SPEED FOR SAFETY FUNCTIONING .....	86
3.8	NOISE ABATEMENT .....	87
3.9	HOVERING .....	88
<b>4</b>	<b>SECTION 4 – EMERGENCY PROCEDURES .....</b>	<b>91</b>
4.1	DEFINITIONS: .....	91

---

4.2 EMERGENCY LIGHTS .....	92
4.3 ENGINE FAILURE AND MALFUNCTIONS .....	94
4.3.1 ENGINE FAILURE – FLIGHT / AUTOROTATION .....	95
4.3.2 EMERGENCY DESCENT .....	96
4.3.3 ENGINE FAILURE - HIGH HOVER .....	96
4.3.4 ENGINE FAILURE - LOW HOVER.....	96
4.3.5 AIR RESTART PROCEDURE .....	96
4.3.6 EMERGENCY ENGINE SHUT DOWN - GROUND.....	97
4.3.7 EMERGENCY ENGINE SHUT DOWN – FLIGHT .....	97
4.3.8 THROTTLE CABLE DISCONNECTION.....	97
4.3.9 GOVERNOR FAILURE .....	97
4.3.10 LOW NR .....	98
4.3.11 HIGH NR.....	98
4.3.12 ENGINE OVERHEATING.....	98
4.4 EMERGENCY EXIT .....	99
4.4.1 EMERGENCY DOOR OPENING FROM OUTSIDE .....	99
4.5 FUEL SYSTEM .....	100
4.5.1 LOW FUEL .....	100
4.5.2 FUEL PRESSURE HIGH.....	100
4.5.3 FUEL PRESSURE LOW .....	100
4.5.4 FUEL PUMP 1 FAIL .....	101
4.5.5 FUEL PUMP 2 FAIL .....	101
4.6 ELECTRICAL FAILURES.....	102
4.6.1 SINGLE GENERATOR FAILURE.....	102
4.6.2 DOUBLE GENERATOR FAILURE.....	102
4.7 FIRE EMERGENCIES .....	103
4.7.1 ENGINE FIRE - FLIGHT.....	103
4.7.2 FIRE DURING ENGINE START - GROUND .....	103
4.7.3 ELECTRICAL FIRE/SMOKE - GROUND .....	103
4.7.4 ELECTRICAL FIRE/SMOKE - FLIGHT .....	103
4.8 CLUTCH FAILURE .....	105
4.9 TRANSMISSION MALFUNCTIONS .....	106
4.9.1 MAIN ROTOR CONTROLS BINDING .....	106
4.9.2 MAIN/TAIL GEAR BOX CHIP.....	106
4.9.3 MAIN GEAR BOX OIL TEMPERATURE HIGH .....	106
4.10 TAIL ROTOR FAILURE .....	108
4.10.1 TAIL ROTOR DRIVE FAILURE – LOW HOVER .....	108
4.10.2 TAIL ROTOR DRIVE FAILURE – FLIGHT / HIGH HOVER.....	108
4.10.3 TAIL ROTOR CONTROL SYSTEM FAILURE – LOW HOVER.....	109

---

4.10.4	TAIL ROTOR CONTROL SYSTEM FAILURE – FLIGHT / HIGH HOVER.....	109
4.10.5	TAIL ROTOR CONTROL BINDING – LOW HOVER.....	110
4.10.6	TAIL ROTOR CONTROL BINDING – FLIGHT / HIGH HOVER.....	110
<b>5</b>	<b>SECTION 5 – PERFORMANCE.....</b>	<b>113</b>
5.1	INTRODUCTION.....	113
5.2	AIRSPPEED CALIBRATION CURVE.....	114
5.3	DENSITY ALTITUDE CHART.....	115
5.4	IGE HOVER CEILING VS. MAXIMUM WEIGHT.....	116
5.5	OGE HOVER CEILING VS. MAXIMUM WEIGHT.....	117
5.6	H-V DIAGRAM.....	118
5.7	AUTOROTATION PERFORMANCE.....	119
5.8	CLIMB PERFORMANCE.....	121
5.9	ENGINE PERFORMANCE.....	122
<b>6</b>	<b>SECTION 6 – WEIGHT AND BALANCE.....</b>	<b>124</b>
6.1	INTRODUCTION.....	124
6.2	CENTER OF GRAVITY (CG) LIMITS.....	125
6.3	HELICOPTER WEIGHING PROCEDURE.....	126
6.3.1	AIRCRAFT PREPARATION.....	126
6.3.2	WEIGHING AND BALANCE FORMS.....	127
6.3.3	CORRECTION WEIGHING.....	128
6.3.4	BASIC MASS RECORD FORM.....	129
6.3.5	LONGITUDINAL CG VERIFICATION FORM.....	130
6.3.6	LATERAL CG VERIFICATION FORM.....	131
<b>7</b>	<b>SECTION 7 – USE AND MAINTENANCE.....</b>	<b>133</b>
7.1	INTRODUCTION.....	133
7.2	REQUIRED DOCUMENTS.....	134
7.3	ROUTINE INSPECTIONS.....	135
7.4	REMOVABLE FLIGHT CONTROLS.....	136
7.5	GROUND HANDLING.....	137
7.6	ROAD TRANSPORT AND TRAILING.....	140

**CONTENTS SECTION 1**

<b>1</b>	<b>SECTION 1- DESCRIPTIVE DATA .....</b>	<b>10</b>
1.1	ABBREVIATIONS AND DEFINITIONS .....	10
1.1.1	CONVERSION TABLES .....	13
1.2	GENERAL DESCRIPTION .....	14
1.3	MAIN ROTOR SYSTEM.....	15
1.4	TAIL ROTOR SYSTEM .....	16
1.5	DRIVE SYSTEM .....	17
1.6	FLIGHT CONTROLS .....	19
1.7	CONTROL FRICTION .....	23
1.8	COCKPIT LAYOUT AND ON-BOARD EQUIPMENT.....	24
1.9	COCKPIT INSTRUMENTS .....	25
1.9.1	ADVISORY LIGHTS PANEL .....	26
1.9.2	ECLIPSE NG – ELECTRONIC FLIGHT INSTRUMENT .....	27
1.9.3	VHF RADIO .....	29
1.9.4	TRANSPONDER .....	30
1.9.5	ROTOR/ENGINE TACHOMETER .....	30
1.9.6	ANEMOMETER .....	31
1.9.7	ALTIMETER.....	31
1.9.8	VERTICAL CARD COMPASS .....	31
1.9.9	ADDITIONAL USB SOCKETS .....	32
1.10	ENGINE.....	33
1.11	GOVERNOR.....	36
1.12	CLUTCH.....	38
1.13	FUEL SYSTEM .....	40
1.14	ELECTRICAL SYSTEM.....	43
1.15	COOLANT SYSTEM.....	44
1.16	OIL SYSTEM .....	45
1.17	FRAME AND CABIN .....	46
1.18	LANDING GEAR.....	47
1.19	CIRCUIT BREAKER PANEL .....	48
1.20	HEAD PANEL.....	49
1.21	ALL-ON PANEL .....	50
1.21.1	ENGINE KEY SELECTOR.....	50
1.21.2	ALL-ON PANEL SWITCHES .....	51
1.22	SEATS, BAGGAGES AND BALLAST .....	52
1.23	OIL AND FLUID .....	53
1.24	STANDARD EQUIPMENT CHARACTERISTICS.....	54

---

## 1 SECTION 1- DESCRIPTIVE DATA

### 1.1 ABBREVIATIONS AND DEFINITIONS

<b>AC</b> .....	Alternate Current
<b>AGL</b> .....	Above Ground Level
<b>ALP</b> .....	Advisory Light Panel
<b>ARM</b> .....	Fore-and-aft location along the helicopter fuselage is usually given in terms of distance in meters from the reference data.
<b>CB</b> .....	Circuit Breaker (fuses)
<b>C.G. LIMITS</b> .....	Extreme CG locations within which the helicopter must be operated at a given weight.
<b>CG</b> .....	Center of Gravity. Location along the fuselage at which the helicopter, if hung, would balance. CG is calculated dividing total helicopter moment by total helicopter weight.
<b>CHT</b> .....	Cylinder Head Temperature
<b>DA</b> .....	Density Altitude. Altitude, in feet, corresponding to pressure altitude corrected for OAT.
<b>DC</b> .....	Direct Current
<b>ECU</b> .....	Engine Control Unit
<b>EMS</b> .....	Engine Management System
<b>GEN</b> .....	Device that converts the current supplied by the motor-generator to direct current 12V available for various consumptions.
<b>LPH</b> .....	Fuel consumption in Liters Per Hour
<b>IGE</b> .....	In Ground Effect
<b>ISA</b> .....	International Standard Atmosphere. Exists when pressure is 29,92 inHg, temperature is 15°C at sea level, and temperature decreases 1,98°C per 1000 feet of altitude.

---

<b>KCAS</b> .....	Knots Calibrated Air Speed is speed shown on the airspeed indicator corrected for instrument and position error.
<b>KIAS</b> .....	Knots Indicated Air Speed is the speed shown on the airspeed indicator.
<b>KTAS</b> .....	Knots True Airspeed is an airspeed relative to undisturbed air. It is KCAS correct for pressure altitude and temperature.
<b>MAP</b> .....	Manifold Absolute Pressure is the air absolute pressure, in inches of Hg, in the engine intake manifold.
<b>MGB</b> .....	Main Gear Box
<b>MCP</b> .....	Maximum Continuous Power
<b>MOMENT</b> .....	The weight of an item multiplied by its arm.
<b>MSA</b> .....	Mean Sea level Altitude. Altitude above sea level, in feet, indicated by the altimeter (corrected for position and instrument error) when the barometric subscale is set to the atmospheric pressure existing at sea level.
<b>MTOW</b> .....	Maximum Take Off Weight
<b>NR</b> .....	Main rotor speed, indicated in percentage.
<b>OAT</b> .....	Outside Air Temperature
<b>OGE</b> .....	Out of Ground Effect
<b>PAYLOAD</b> .....	Weight of occupants, cargo and baggage.
<b>PA</b> .....	Pressure Altitude. Altitude, in feet, indicated by the altimeter (corrected for position and instrument error).
<b>RPM</b> .....	Revolutions Per Minute. Engine rotational speed indicated in percentage, considering 5500 RPM as 104%.
<b>REFERENCE DATUM</b> .....	A reference vertical plane from which horizontal distances are measured for balance purposes.

---

<b>STATION</b> .....	Fore-and-aft location along the helicopter fuselage is usually given in terms of distance in millimeters from the reference data.
<b>TGB</b> .....	Tail Gear Box
<b>TOW</b> .....	Take Off Weight
<b>TOP</b> .....	Take Off Power. Maximum power for 5 minutes.
<b>UNUSABLE FUEL</b> .....	Fuel remaining in the tank that is not usable.
<b>USABLE FUEL</b> .....	Fuel available for flight planning.
<b>USEFUL LOAD</b> .....	Difference between maximum takeoff weight and basic empty weight.
<b>V<sub>NE</sub></b> .....	Never-Exceed Airspeed: speed not to exceeded to avoid aerodynamic and/or structural problems.
<b>V<sub>H</sub></b> .....	Speed achieved using MCP.
<b>V<sub>Y</sub></b> .....	Speed for best rate of climb.

## 1.1.1 CONVERSION TABLES

<b>Multiply</b>	<b>Unit</b>	<b>by</b>	<b>To obtain</b>	<b>Unit</b>
Feet	ft	0.3048	Meters	mt
Inches	in	2.54	Centimeters	cm
Nautical Miles	nm	1.852	Kilometers	Km
Statute Miles	mi	1.604	Kilometers	Km
Gallons US	gal	3.7854	Liters	l
Pounds	lb	0.4536	Kilograms	Kg
Quarts	qt	0.9464	Liters	l
Centimeters	cm	0.3937	Inches	in
Kilograms	Kg	2.2046	Pounds	lb
Liters	l	0.2642	Gallons US	gal
Liters	l	1.0567	Quarts	qt
Kilometers	Km	0.5400	Nautical Miles	nm
Kilometers	Km	0.6214	Statute Miles	mi
Meters	m	3.2808	Feet	ft

## 1.2 GENERAL DESCRIPTION

The Lamanna ESCAPE is an ultralight helicopter (ULH) with a maximum takeoff weight of 600 kg. The helicopter is a single-engine, piston-powered type, featuring a two-blade main rotor and tail rotor, skid landing gear, and a two-seat composite cockpit.

The ESCAPE is designed as a touring aircraft and a basic trainer.

The helicopter is equipped and certified exclusively for daytime VFR flight.

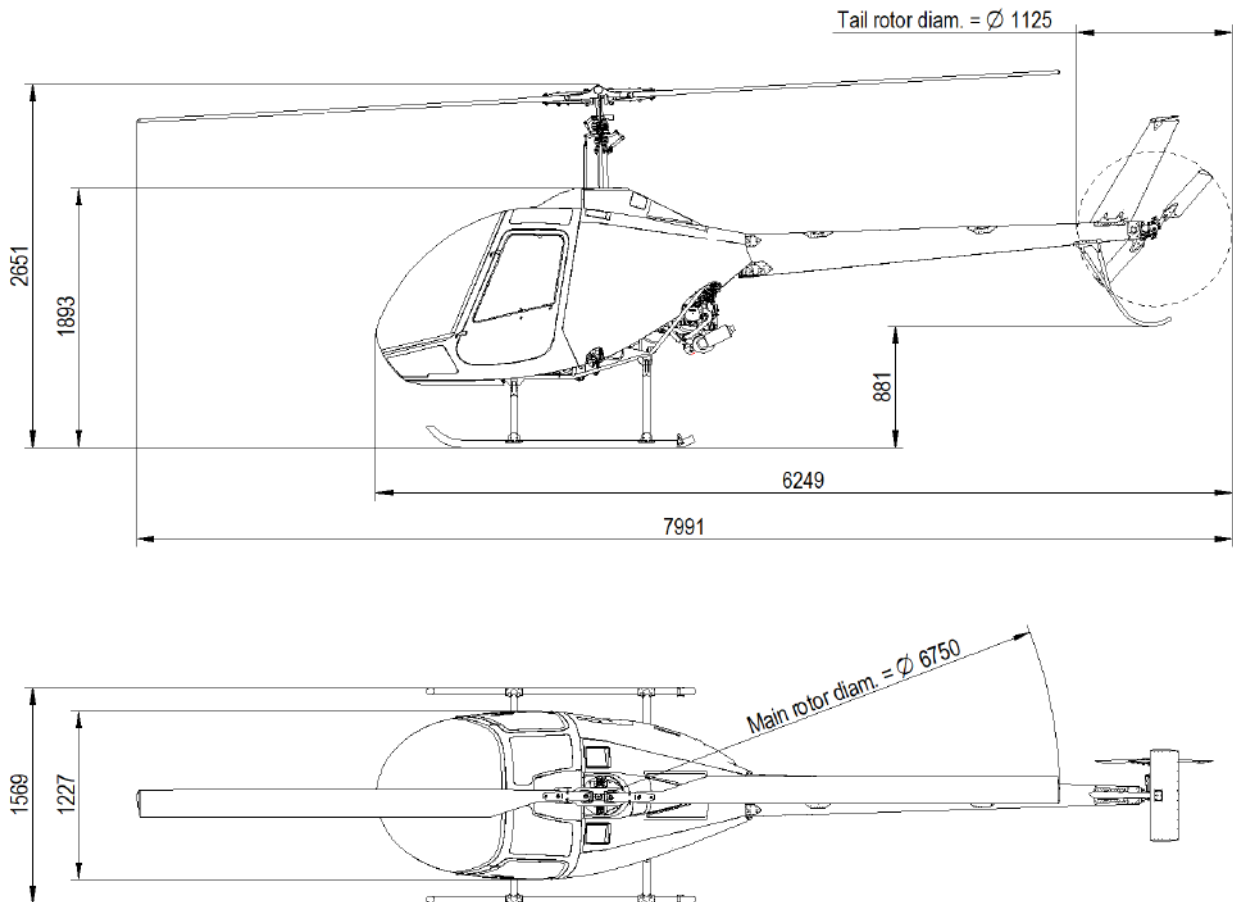

1.3 MAIN ROTOR SYSTEM

It is formed by two blades in composite material, fixed to the hub through anchoring plates. The hub is mounted on the mast with a flapping hinge above the blade anchoring plate. The blades are protected with plastic material all along the leading edge to shield against corrosion and erosion of atmospheric agents, sand, etc.

The pitch change hinge of each blade is located partly in the rotor hub and partly in the pitch change block, placed behind the blade anchoring plates. This block contains an elastomeric group that allows the change of pitch counteracting the centrifugal force. The flapping hinge uses shielded needle roller bearings. The blade's static stops are applied to the rotor hub and are designed to get damaged pre-emptively if they get in contact with the mast, therefore warning that there is the need of an inspection.

DESCRIPTIVE DATA

Number of Blades	2
Diameter	6.75 mt
Blade Chord	200 mm
Blade Twist	6°
Rotational Speed at 104%	540 RPM

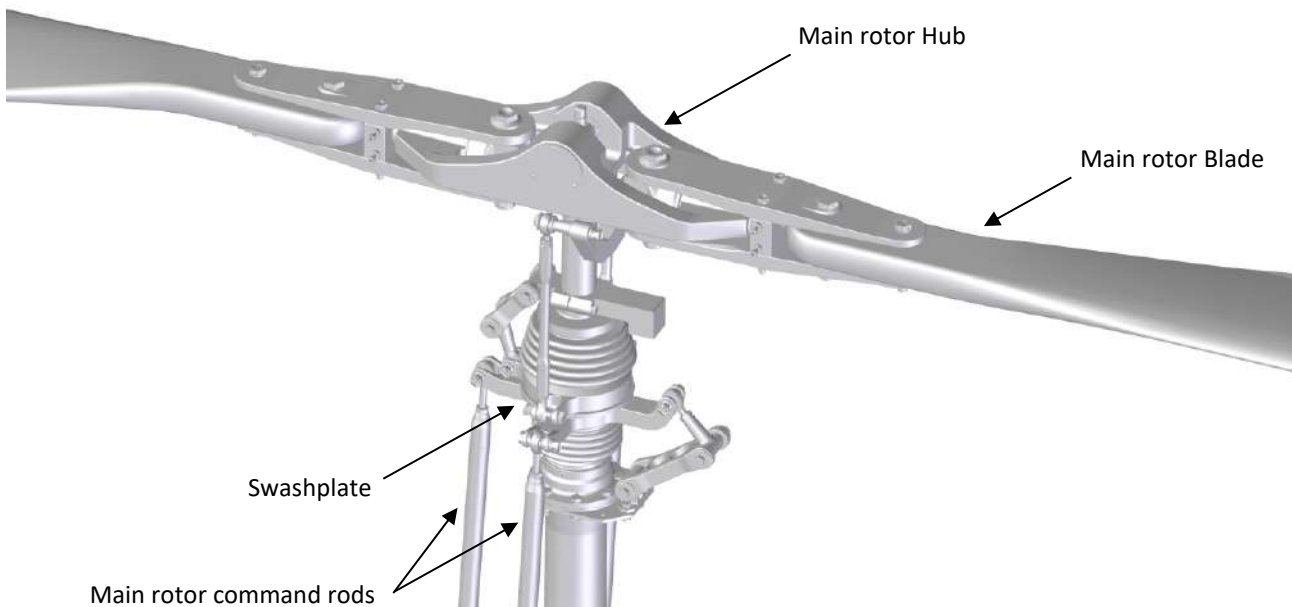

## 1.4 TAIL ROTOR SYSTEM

The tail rotor is formed by two blades in aluminum alloy and a flapping hub with a fixed coning angle. On each blade tip edge an orifice is present to drain out any moisture inside the blade, preventing internal corrosion and unbalance conditions. The pitch-change and the flapping bearings are forced lubricated with PTFE parts.

### DESCRIPTIVE DATA

Number of Blades	2
Diameter	1.125 mt
Blade Chord	Tapered
Rotational Speed at 104%	3200 RPM

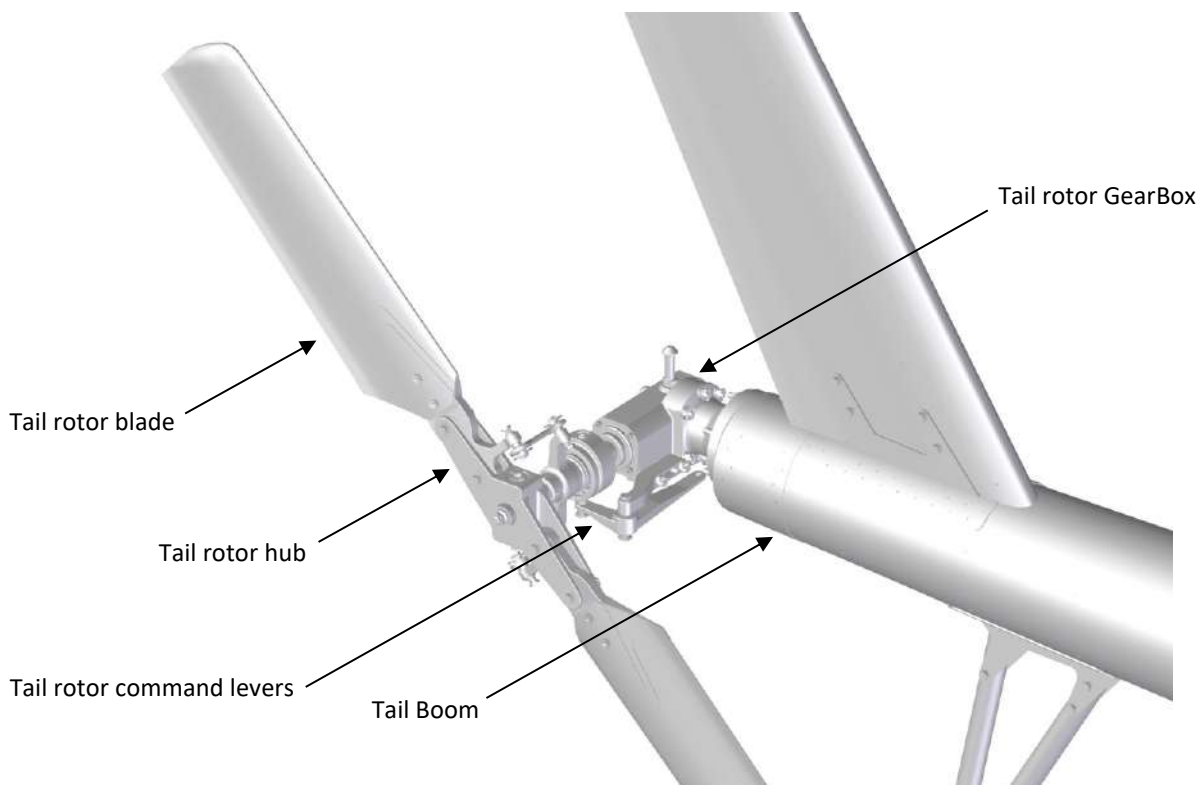

1.5 DRIVE SYSTEM

A double-vee belt pulley is bolted directly to the engine output shaft. The vee-belts transmit power to the upper pulley, which then transfers it to the MGB and TGB through a dual output, applying also an initial RPM reduction. Power transfer between the two pulleys is made possible by an electrically actuated clutch. Inside the upper pulley, there is a free-wheel unit that, in the event of an engine power loss, allows autorotation.

Flexible couplings are located at the MGB input and at each end of the tail rotor drive shaft in order to damp down vibrations.

The MGB is installed on the helicopter with 2 lower and 3 upper elastic joints (MDS) containing a single-stage spiral-bevel gear set which is forcedly lubricated. The long tail rotor transmission shaft has 2 bearings mounted on elastic joints. Also, the TGB contains a single-stage spiral-bevel gear set which is splash lubricated. The input and output TGB shafts are made of treated steel to prevent erosion.

An electric actuator, located between the drive sheaves, moves down the lower sheave when the pilot engages the clutch switch on the “All On Panel”. The actuator senses compressive load (belt tension) and switches off when the vee-belts are properly tensioned. The clutch caution red light illuminates whenever the actuator circuit is energized, either engaging, disengaging, or re-tensioning the belts. The light stays on until the belts are properly tensioned or completely disengaged. A low amperage fuse prevents actuator motor overload.

**WARNING**

Never take off with the clutch warning light on.

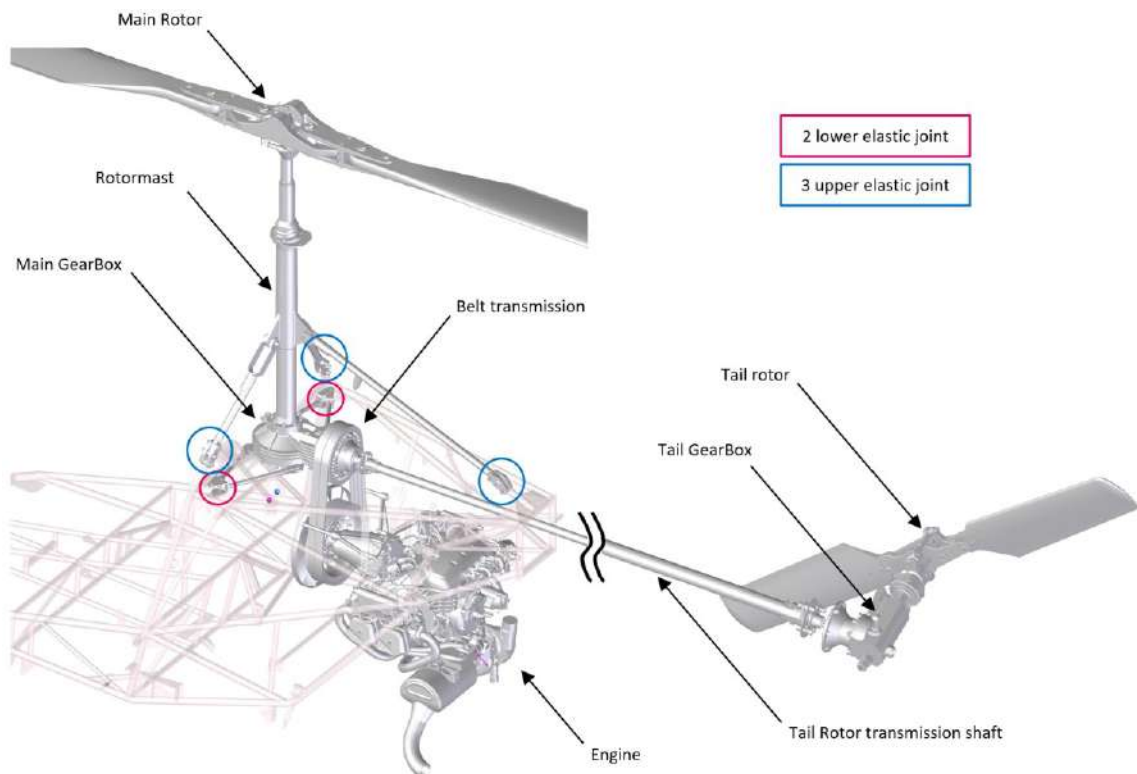

The Thomas coupling is used to connect the tail rotor drive shaft to the main transmission. In this application it performs a critical function: it transmits the torque, compensates for minor structural misalignments caused by airframe flexion in flight, and absorbs vibrations preventing them from being transmitted along the tail rotor shaft.

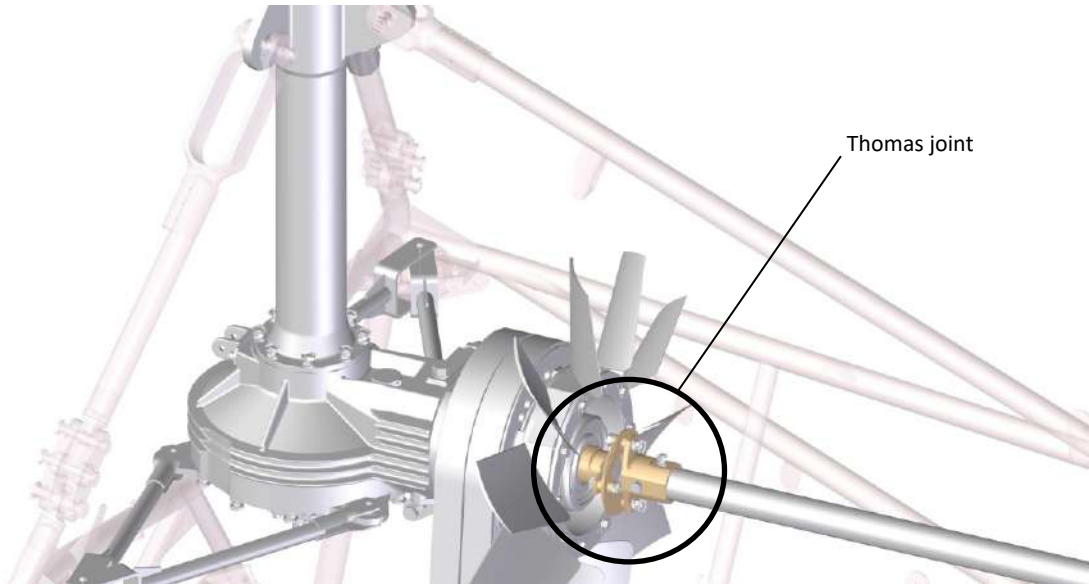

---

## 1.6 FLIGHT CONTROLS

The standard flight control system includes command for the second pilot or the instructor. All controls are actuated through push-pull rigid tubes and bell cranks. Bearings used throughout the control system are either sealed ball bearings or self-lubricated Teflon bearings.

ESCAPE flight controls are conventional. The cyclic control is “T-shape”, acting directly on the swashplate, as for every helicopter. The control handle is free to turn up and down to adapt to pilot’s characteristics. The left cyclic includes five control buttons and one 4-way selector. The five pushbuttons are designed to be used as remote control for specific instruments, allowing access to their functionalities without removing the hand from the cyclic. Their functions are:

- **A:** remotely activate the first bottom-left pushbutton of the Eclipse NG screen.
- **B:** remotely activate the second bottom-left pushbutton of the Eclipse NG screen.
- **D:** “DELETE” function for the Eclipse NG.
- **Sk:** scroll the list of frequencies saved in the VHF radio memory.
- **Tk:** confirm and activate the selected frequency from the VHF radio memory.
- **4-way sel.:** lateral and longitudinal trim activation.



Collective control is located at the left of each seat. The throttle grip commands engine rpm changes through a mechanical linkage. In order to reduce pilot workload, a governor system has been implemented, that automatically change engine rpm in accordance to the power requirements dictated by the collective position. Four switches are present only on the left collective handle, which are:

- BBS: ON/OFF the Backup Battery System
- STARTER: Engine start
- GOV: ON/OFF governor
- COLETV: UP/DWN collective trim (SCS trim)



The pedals, through a series of connecting rods, activate the push-pull tubes and bell cranks on the TGB, to change the tail rotor blade pitch, this way controlling the yaw rate. Servo control springs are installed on collective and cyclic controls to reduce the piloting forces.



Cyclic control is equipped with longitudinal and lateral trim, to reduce the required forces on that ax. Both trims are spring type, where an electric actuator change the spring tension to reduce pilot effort during cruise flight. A 4-way selector on the cyclic handle, activates the electric actuators. By moving the joystick upward and downward the longitudinal trim is activated (Trim Long); by moving it laterally the lateral trim is activated (Trim Lateral). The amount of displacement is indicated by the relative window with an illuminated scale, on the

dedicated trim panel beneath the “All-On-Panel” on the central console. A selector named “Trim SW LH/RH” is used to define which cyclic trim joystick (left or right) is controlling the longitudinal and lateral trim actuator.

Collective is also equipped with a spring system called SCS (Servo Collective System), which helps to balance rotor’s loads, allowing the pilot to feel minimum or zero force on the collective. The SCS is adjusted through the dedicated switch on the left collective grip. By selecting UP or DWN the neutral point is moved toward the selected direction, varying the spring load and, consequentially, the sensed force. Two dedicated lights, named “Trim Collective UP/DWN”, light up only when the collective trim has reached its full displacement, both up or down. During the operation of the collective trim in intermediate positions, the system does not provide any indication.



## 1.7 CONTROL FRICTION

Cyclic and collective controls are equipped with adjustable friction devices.

A toggle type lever is located near the aft end of the right collective lever. If it is moved up, friction is increased, if it is moved down, friction is decrease.

The cyclic friction knob is in the right side of the cyclic collum, so that it is accessible to both pilots. Turning the knob clockwise applies friction to both longitudinal and lateral direction. Friction is normally applied only on the ground.

### CAUTION

Control friction must be used with caution if applied during flights, to avoid inadvertent locking of controls.



1.8 COCKPIT LAYOUT AND ON-BOARD EQUIPMENT

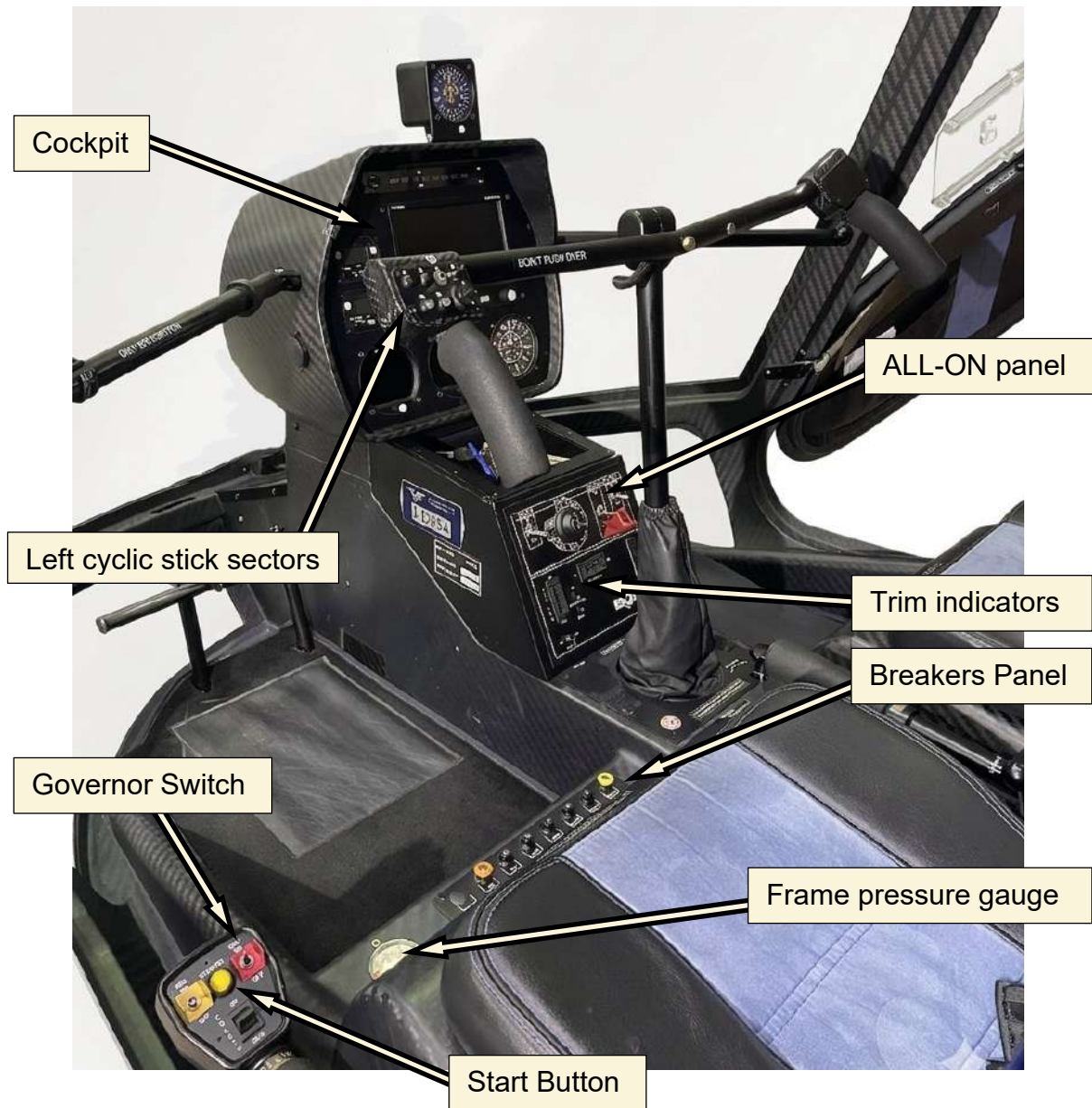

1.9 COCKPIT INSTRUMENTS

The cockpit instrument panel is divided in three main sections: the Advisory Lights Panel, the primary flight instruments (ECLIPS, VHF radio and Transponder) and the back-up instruments (rotor/engine tachometer, air speed and altitude indicator).



1.9.1 ADVISORY LIGHTS PANEL

The Advisory Lights Panel (ALP) indicates the status of the helicopter main systems and some specific critical conditions and is located on the upper part of the instrument panel. For more detailed information about the emergency lights bas, refer to paragraph 4.18. Additional indications are provided by the ECLIPSE instrument panel.



1

1	ALP test button	LWF	Low fuel
MCP	Main Chip Detector	GOV	Governor
TCP	Tail Chip Detector	CLT	Clutch
FP1	Fuel pump 1	STU	Start Unit
FP2	Fuel pump 2	BBS	Backup Battery Switch

1.9.2 ECLIPSE NG – ELECTRONIC FLIGHT INSTRUMENT

The Eclipse NG is an electronic avionic suite used both as Engine Management Unit (EMU) and primary flight instrument. Thanks to its capability to present multiple pages, the pilot can monitor multiple aspects about the flight, increasing his situational awareness. The EMU is protected by the “EMU” circuit breaker.

The data presented are related to the following:

- Checklists
- Flight path
- Rotor-Engine tachometer
- Engine parameters
- Transmission parameters
- Fuel parameters
- Electrical parameters

**CHECKLIST**

Enabling the checklist page, it’s possible to have access to the “Engine start” and “Engine shut down” checklist only. The element shown on the digital checklist represents an abstract of the steps presented in the relative checklists reported in this manual. The checklist page can be accessed via the push button at the bottom of the screen.



**FLIGHT PATH**

This is the main flight page, representing a digital attitude display indicator (ADI) associated to all the main information related to the flight path like pitch, roll, altitude, speed, vertical speed, G-meter and heading. A “blue-on-brown” picture, where the brown represents everything below the horizon (water or land) and the blue everything above it (sky or high terrain like mountains), is used to understand the helicopter attitude in relation to the horizon. In this representation the aircraft symbology remain fix, while the horizon line moves in accordance to the profile flown.

A graduated scale is used to visualize the angle of pitch change and the rolling angle.

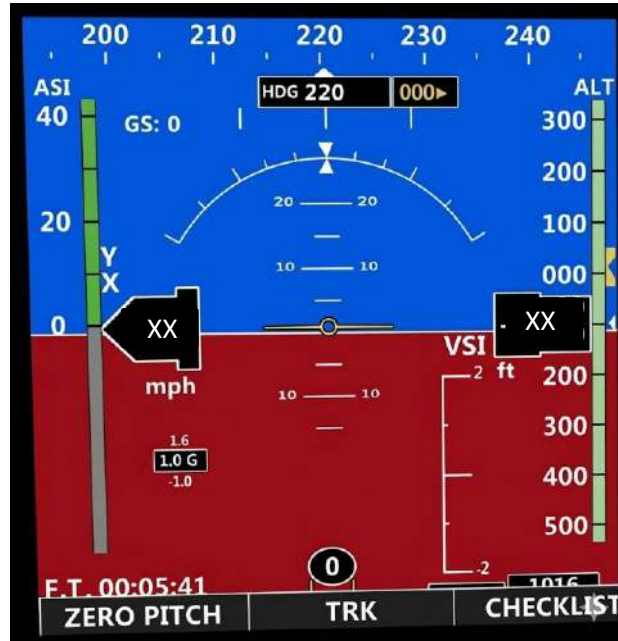

**ROTOR-ENGINE TACHOMETER**

Rotor and engine tachometer are presented on the upper right side of the screen. These indicators are color coded in accordance to the helicopter specification and, next to the bottom of the needle, a digital readout of the relative exact value in percentage is shown. At the bottom of the indicators, the MAP value and the status of the “Line A” and “Line B” is presented.

This section of the page is always visible, even if other pages are activated. The only exception is when the page showing the transmission layout and status is displayed. In this case the rotor-engine tachometer is not displayed.

**CAUTION**

In this condition, refer to the stand by tachometer for NR management.



*ENGINE, TRANSMISSION, FUEL & ELECTRICAL PARAMETERS*

Four additional pages can be activated on the right bottom of the screen, giving access to different systems information, as shown below. Scrolling the pages can be done using both the pushbutton at the bottom of the screen or using the dedicated pushbutton on the left cyclic.

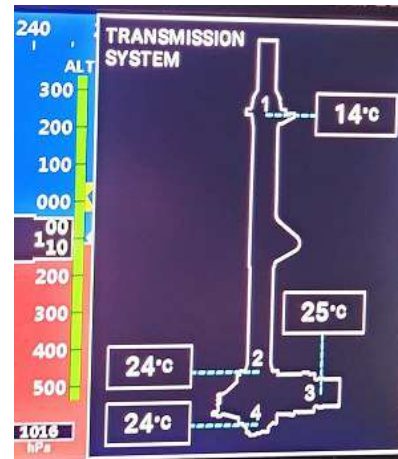
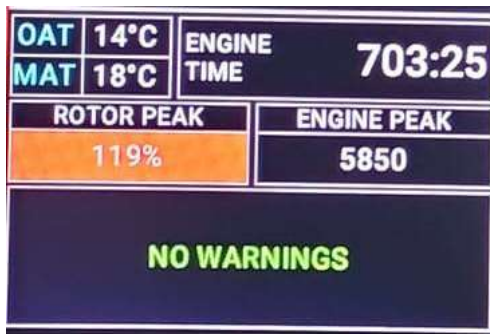
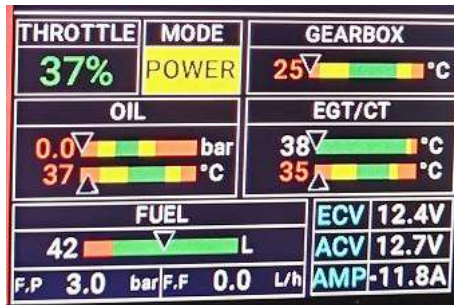

NOTE: REFER TO ECLIPSE MANUAL

1.9.3 VHF RADIO

The ESCAPE is equipped with one VHF radio, installed in the instrument panel. For details on how to operate and functionalities, refer to the radio manual.



#### 1.9.4 TRANSPONDER

The ESCAPE is equipped with one transponder, installed in the instrument panel. For details on how to operate and functionalities, refer to the transponder manual.



#### 1.9.5 ROTOR/ENGINE TACHOMETER

The ESCAPE is equipped with one mechanical standby rotor/engine rpm indicator, installed in the instrument panel. The instrument shows two independent scales, one for the main rotor rpm (left) and one for the engine rpm (right). The two scales are graded and color coded based on main rotor and engine operational conditions.

The specified value of high or low NR in autorotation is highlighted by a box of the respective color (yellow or red).



### 1.9.6 ANEMOMETER

On the instrument panel is located a mechanical standby anemometer. The speed scale is graded in both MPH and KTS. The color code is based on the characteristic speeds of the ESCAPE helicopter.



### 1.9.7 ALTIMETER

The ESCAPE is equipped with one mechanical standby altimeter, located on the instrument panel. Through a dedicated knob, is possible to select the reference barometrical pressure.



### 1.9.8 VERTICAL CARD COMPASS

The helicopter is equipped with one vertical compass indicator, installed above the instrument panel. The correction placard is located under the compass.



### 1.9.9 ADDITIONAL USB SOCKETS

There are one 12 V USB ports and two 5 V USB ports, located on the left side of the instrument panel, to connect external devices. The 12 V USB port, labeled “GPS”, is dedicated to external GPS devices, to use the helicopter GPS signal as reference signal for their operations. The two 5 V USB ports, labeled as “PHONE”, are protected by a rounded cap, and can be used to charge phones or other portable electrical devices.

One other USB port is located on the right lower side of the instrument panel. This port is dedicated exclusively to the ECLIPSE instrument, for data upload or maintenance actions. All ports are protected by their CB.

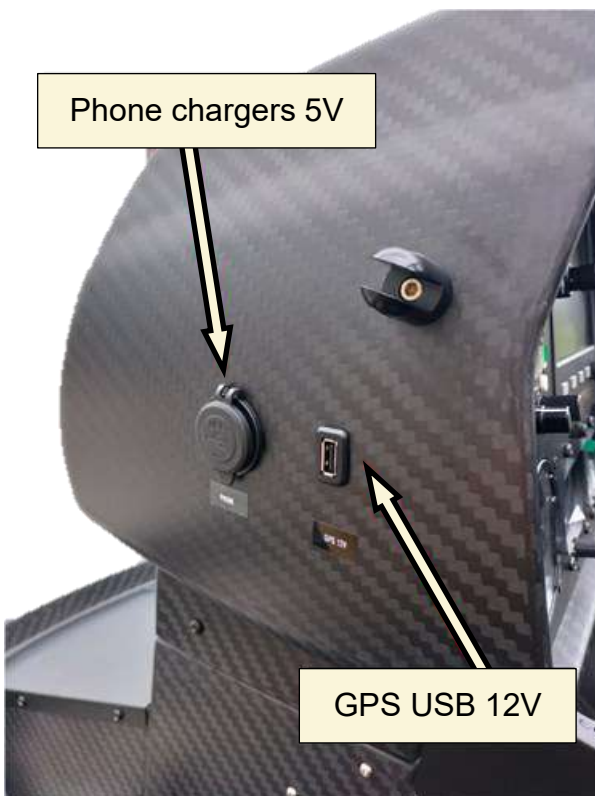

## 1.10 ENGINE

The ESCAPE helicopter is powered by a Rotax 915 iS TYPE A Turbo Injection engine, with four cylinders horizontally opposed.

The engine is equipped with an electric starter, an oil pump with dedicated heat exchanger water/oil for lubrication and cooling oil system and a water pump with the radiator for refrigerant cooling. To increase reliability the engine is equipped with a double injection system, double wiring and two spark plugs per cylinder.

The turbo is located on the right side of the engine, along the exhaust gas line, and it is equipped with a washable filter that filters the incoming air. The air, after being compressed, goes through an intercooler to be cooled down, located under the right engine compartment door. The cooler air is then directed to the engine intake manifold, where is then used by the engine. There is no need for a heating device for the turbo, due to its high temperature working conditions.

A double fan air-forced system is used to cool down the engine coolant radiator. The design is such that both in hovering and in low-speed conditions, the air goes through the radiators and brushes the hot parts of the engine. This system is made by a fan coaxial to the upper transmission sheaves, that force the airflow through a duct made of composite material, which channels part of the air into the radiators and part around the engine.

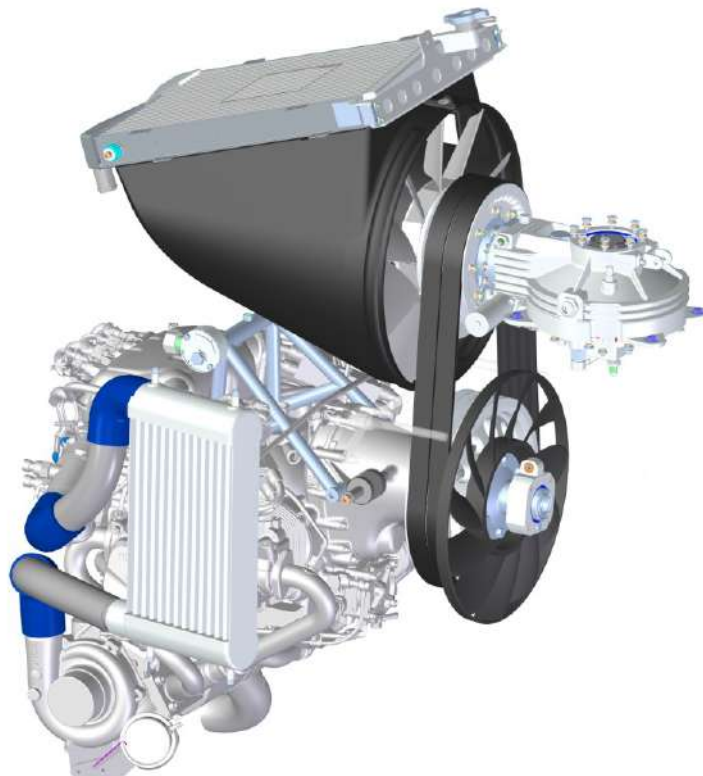

A twist-grip handle (throttle) at the end of each collective stick regulates engine power, directly acting on the engine throttle lever through a cable. The throttle does not include a direct shutdown position. Instead, it provides two positions: idle and full open.

The throttle IDLE position is maintained by a balance force between the internal throttle spring (inside the collective grip) and the engine throttle lever. This position can be seen as a “SOFT IDLE”. It is possible to the pilot to act against the internal collective spring and overrun the soft idle position to a further reduced throttle position, hitting the mechanical stop, so called “HARD IDLE”. Releasing the pressure will set the throttle back to the soft idle position, corresponding to 36% of the engine throttle lever. The throttle spring and the engine throttle lever works in continuous antagonism. The presence of this double spring system allows, in the event of a cable failure, the immediate reduction of the engine throttle lever to its minimum operating RPM. This prevents the occurrence of anomalous engine response (constant or high RPM) that might affect main rotor safe operations. At this point, a controlled and safe autorotation maneuver can be performed.

For practice autorotation, twisting the grip to the hard idle position, prevents the engine throttle lever from being opened by the governor system when the collective is raised during the flare, causing an unwanted reengagement of the free-wheel.

On the top collar of the left throttle grip there is a mark, that moves with the handle rotation; opposite to that there are two points marked as “HOT” and “COLD”. These two points, indicating respectively the 36% and 41% of throttle opening, indicate the point to which the throttle marker should be align, based on engine temperature, to set the proper IDLE condition.



Correct throttle link adjustment may be verified during pre-start checks, by rolling the throttle grip through to the hard IDLE stop and completely rise the collective. In this condition the engine throttle value reported in the ECLIPS should be below 45%.



Engine Type	- Rotax 915 iS A Turbocharger Injection - 4-stroke, 4 cylinders horizontally opposed - Double injection system - Intercooler system - Engine Control Unit (E.C.U.)
Displacement	- 1352 cc
Nominal rating	- 104 kW for 5 min max
Continuous power	- 99 kW
Critical Altitude	- 15000 ft
Maximum Operating Altitude	- 23000 ft
Cooling system	- mixed liquid/oil/air

**NOTE:** See Rotax Engine Operators Manual for further details.

## 1.11 GOVERNOR

The governor is design to maintain constant engine and main rotor RPM inside limits during normal operations. The reference values are those related to the green arch.

The governor can be engaged only above 80% of engine RPM, using the dedicated selector switch on the left collective. The switch is guarded by a red guard to prevent unintentional activation or deactivation. The governor can be deactivated in any moment during flight, or ground, by switching the selector in OFF position. The governor OFF condition is indicated in the ALP with a white light "GOV".

With the governor ON, the engine throttle, located on the collective grip, is correlated to collective inputs through a mechanical linkage: the throttle is automatically opened when the lever is moved to an increased collective pitch, and vice versa. The governor is designed to assist the pilot in controlling RPM under normal flight conditions, by keeping the engine RPM at 5500 and the main rotor speed at 104% (MCP). If any power above MCP is required, the pilot need to override the governor by physically rotate the throttle until reaching the desired value of engine RPM.

The pilot override is made possible by a rotative clutch in series with the governor line of control. When the pilot apply force on the throttle a slip is generate on the clutch, that allow the pilot input to pass through and reaching the engine.

The governor system does not prevent under/over-speed due to aggressive flight maneuvers. In these cases, the pilot has to apply minor throttle correction to maintain the parameters inside limits.

The governor, by comparing engine and main rotor rpm, is the one that in case of low or high NR, activate an acoustic alarm. The trigger values, related to the autorotational condition, are the following:

LOW NR :	94%
HIGH NR :	108%

This conservative values, compared to the real NR limits, are intended to warn the pilot before reaching the limits of the autorotational NR envelope. Manual deactivation of the governor, does not interfere with the NR warning functionality.

The operation of the governor system is indicated by a white light on the light panel.

### **CAUTION**

Disengagement of the governor in flight leave the pilot in full control of engine and main rotor RPM. Attention must be use to prevent under/over-speed of both systems.



## 1.12 CLUTCH

The clutch system is based on an electric actuator connected to the lower part of the MGB and the engine power shaft. When activated, by switching ON the clutch selector on the “All on Panel”, the electric actuator pushes downward the inferior sheave, tensing the vee-belts. The actuator is equipped with a load sensor, that is calibrated to the proper belt tension. When the belts are properly tensioned, the sensor switches off the actuator.

The clutch warning light (CLT) on the advisory light panel illuminates whenever the actuator circuit is energized, either engaging, disengaging, or re-tensioning the belts. The light stays on until the belts are properly tensed or completely disengaged.

During flight might happen that, for environmental conditions, the belts need to be re-tightened. In this case the actuator is automatically activated and the process is indicated by the illumination of the CLT warning light on the Advisory Light Panel. It is acceptable to have quick and sporadic activation of the CLT light during flight, but for a maximum of 3 consecutive seconds. Over 3 seconds, refer to the emergency procedure.

The system is protected by a dedicated CB “CLUTCH”, identified by a yellow collar.

### **WARNING**

Never take off with the clutch warning light on.

**Clutch representation in the system:**

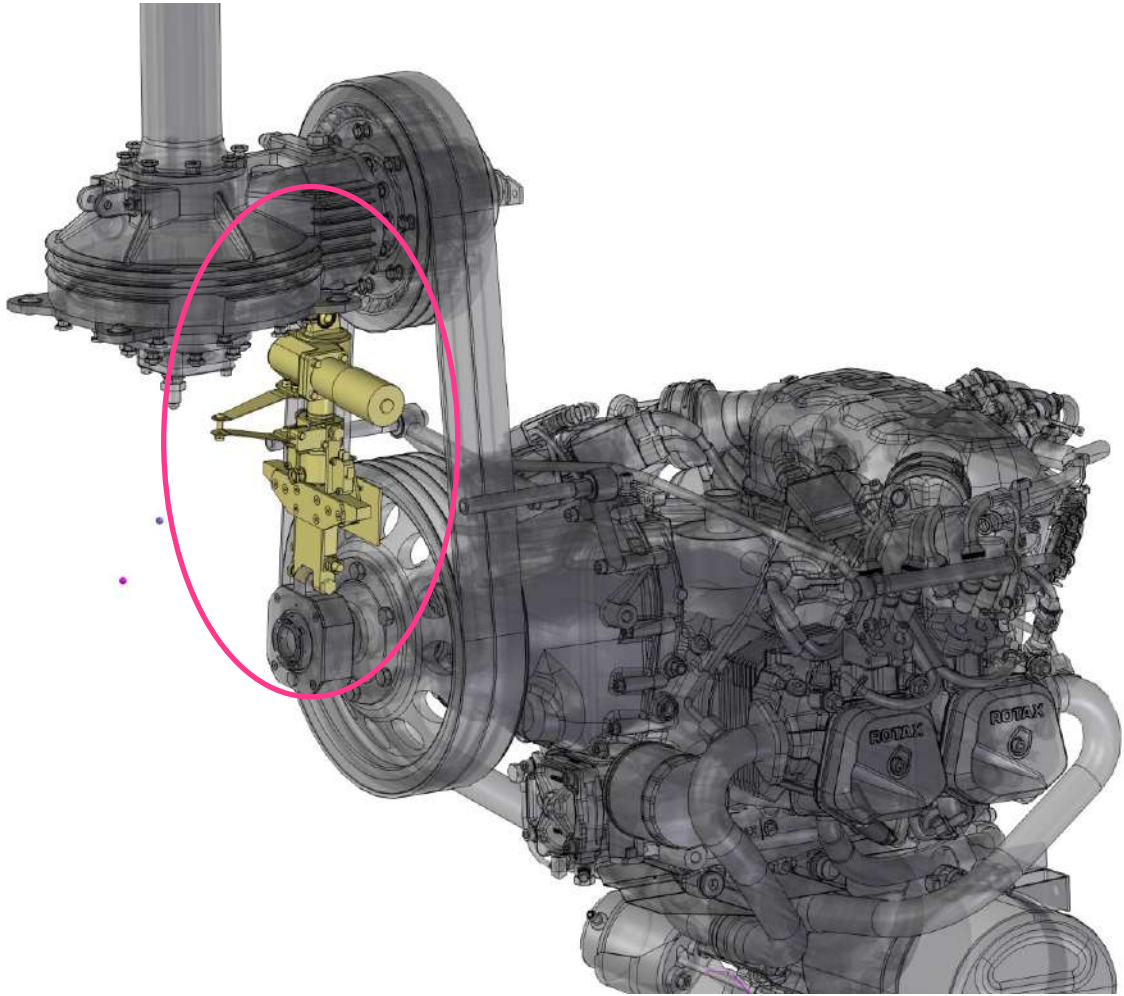

**Clutch breaker representation in the BREAKER PANEL:**



1.13 FUEL SYSTEM

The main components of the fuel system are the tank, two fuel pumps, a fuel shut-off valve, filters, and vent lines.

**Cycle block diagram:**

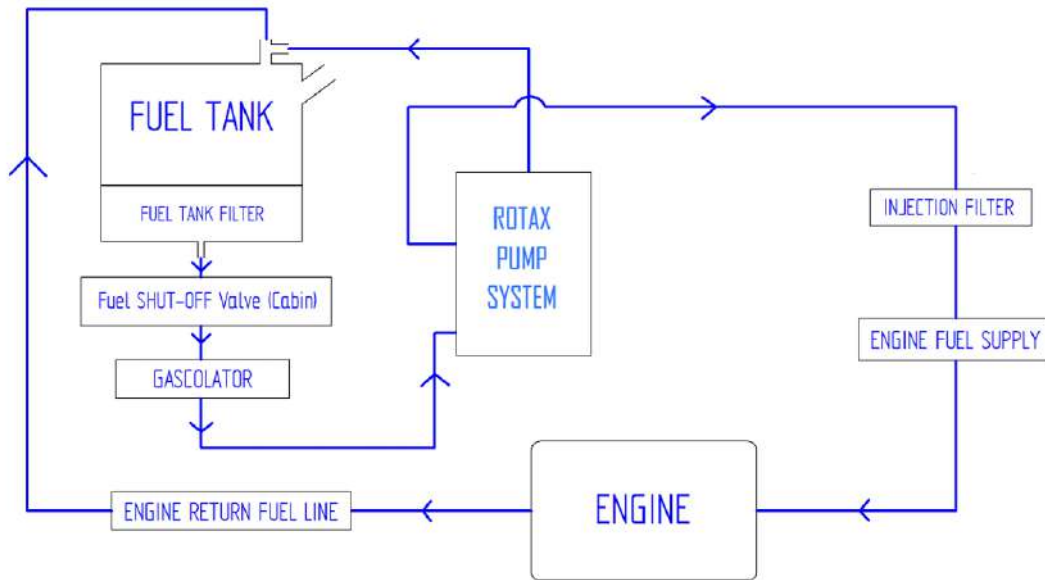

The tank, located behind the cabin, is made of semi-transparent plastic and has a capacity of 65 liters (90 liters optional). On the side facing the engine, it is fitted with a fire-resistant lining. The refueling filler neck is located on the right side of the fuselage and is protected by a lever-lock cap.

Fuel level is measured by a capacitive system, which sends an electrical signal to the EMU, where it is displayed on the ECLIPSE instrumentation.

A low fuel level sensor is installed in the lower part of the tank. This sensor operates independently of the fuel quantity indicator and is activated when the remaining fuel level drops below 15 liters, corresponding to approximately 20 minutes of remaining flight time. Reaching the minimum level is indicated by the “LWF” warning light on the ALP.

Two vent lines, one connected to the upper left part of the tank (line 1) and the other to the filler neck (line 2), ensure tank ventilation and pressurization during normal operation. The two lines are cross-connected, with the left line venting on the right side and vice versa. This configuration prevents any fuel leakage in the event of a helicopter rollover, since the vent of at least one of the two lines will always be positioned above the fuel level in the tank.

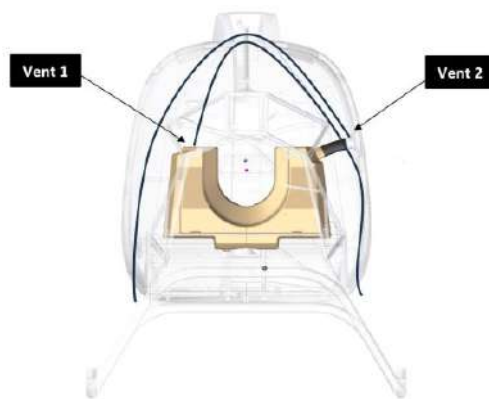

The fuel system has a two different drainage system:

Tank drainage:

The internal geometry of the tank has been designed with specific slopes converging toward the lowest point. In the normal ground parking position, the orientation of the bottom ensures that water and any contaminants denser than fuel naturally flow toward the drainage sump, preventing stagnation pockets in other areas of the tank.

The internal filter is a metal mesh type and prevents solid contaminants from entering the fuel line.

Fuel System drainage:

The gascolator is positioned at the lowest point of the fuel system to ensure complete drainage of the system, via a dedicated manual valve.

It is recommended to carry out drainage operations with the helicopter levelled.

From the fuel tank, the fuel flows through the shut-off valve located in the cockpit between the two seats. From there, it reaches the gascolator, which filters the fuel before it continues toward the pumps. Closing the shut-off valve stops the fuel flow, causing the engine to shut down in less than 3 seconds at idle. Subsequently, an additional filter ensures complete removal of impurities before the fuel enters the pumps.



The fuel is then pressurized by two pumps: pump 1 (primary) and pump 2 (secondary). In the event of a malfunction or failure of one pump, the other is fully capable of meeting the engine's requirements during flight. The pump failure is indicated by the illumination of the "FP1" or "FP2" lights on the ALP. The fuel line is equipped with a system that prevents air bubbles from entering the fuel line and an overpressure relief valve.

After passing through an additional filter (injection filter), the fuel reaches the injection system, from which it is delivered to the engine. Pressure and fuel flow sensors inside the engine send data to the EMU for display on the ECLIPSE monitor. Any excess fuel is redirected to the fuel tank trough the return line.

Fuel

Super or Unleaded gasoline for car

Octane rating is not lower than MON 85 o RON 95 (preferably unleaded)

100 LL grade Aviation Fuel

## 1.14 ELECTRICAL SYSTEM

The electrical system consists of a single stator shared by two separate alternators. The alternating current (AC) produced by the two alternators is then converted into direct current (DC) by two rectifier units, one for each alternator. The alternator–rectifier assembly is referred to as a “generator”, namely GEN 1 (14.2 V DC – 16 A – 220 W) and GEN 2 (14.2 V DC – 30 A – 420 W). Completing the system is a 12.8 V – 10 Ah lithium battery, located behind the instrument panel.

The selection of which generator is powering the Engine Management System (EMS) depends on the engine status and can only be done by the Engine Control Unit (ECU).

During the engine start phase, the EMS is powered by the Backup Battery System (BBS) until the engine reaches 3000 RPM. At that point, GEN 2 supplies power to the EMS, but only for the time required to complete the operational checks, after which GEN 1 takes over, powering the EMS exclusively. GEN 2 then powers the onboard instruments and maintains the battery charge. In no operation state can GEN 1 be used to supply onboard instruments and utilities.

In the event of a GEN 1 failure, GEN 2 takes over the EMS load, leaving the battery to supply power to all onboard instrumentation, which will no longer be recharged. A similar condition occurs in the event of a GEN 2 failure, where the EMS continues to be powered by GEN 1, while the battery must support all other electrical loads, again without being recharged.

The BBS is designed to allow the battery to directly power the EMS in flight; it is required in the case of a dual generator failure. The switch is located on the left collective lever, guarded by a yellow safety cover to prevent accidental activation. Under normal conditions the switch is set to OFF; when set to ON the battery directly powers the EMS, along with the various onboard instruments and associated systems. Activation of the BBS is indicated by the yellow “BBS” light on the annunciator panel.

During ground start the BBS is automatically connected to the EMS, even if the switch is in the OFF position, and is then automatically replaced by the generators. Should both generators fail, the EMS would permanently lose electrical power, causing engine shutdown. In this condition the only electrical power source available for an emergency restart would be the battery, via the BBS circuit.

With both generators lost and the BBS active (engine restarted), battery endurance will vary depending on several factors, like environmental conditions and electrical load. Plan to land as soon as possible, otherwise the engine may shut down again.

Both generators and the battery are monitored by the ECLIPSE instrument system, which displays their operational status and faults.

The ECU uses two data modules for the engine monitoring, called “LINE A” and “LINE B”; each of them is capable of controlling, regulating and monitoring the engine. In normal conditions the ECU receives data from the various engine sensors, which then send to both lines. In case of failure of one of the two modules, the ECU will automatically select the working one.

The electrical system is protected by a series of push-to-reset circuit breakers (CB), one for each installed load, as indicated by the label beneath each of them. The CB panel is located in front of the left seat. The “CLUTCH” CB is highlighted with a colored collar to facilitate identification during emergency procedures.

1.15 COOLANT SYSTEM

The ESCAPE cooling system utilizes a coolant mixture diluted with demineralized water. The cooling cycle is managed by a water pump powered by the engine that circulates the fluid through the engine to absorb heat.

The hot water then enters the radiator, where it is cooled by forced airflow. To ensure a constant airflow in all flight conditions, the system features a fan powered by the main transmission, embedded in a carbon-fibre case attached to the radiator, design to optimize the airflow cooling efficiency.

After exiting the radiator, the cooled water passes through the oil-coolant heat exchanger before returning to the pump, ensuring the engine remains within safe thermal operating limits.

**Cycle block diagram:**

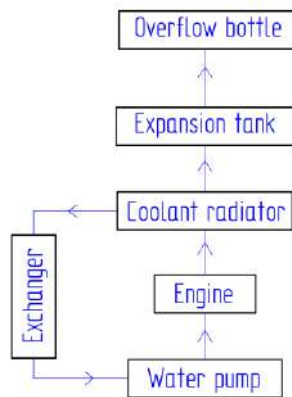

**Installation layout:**

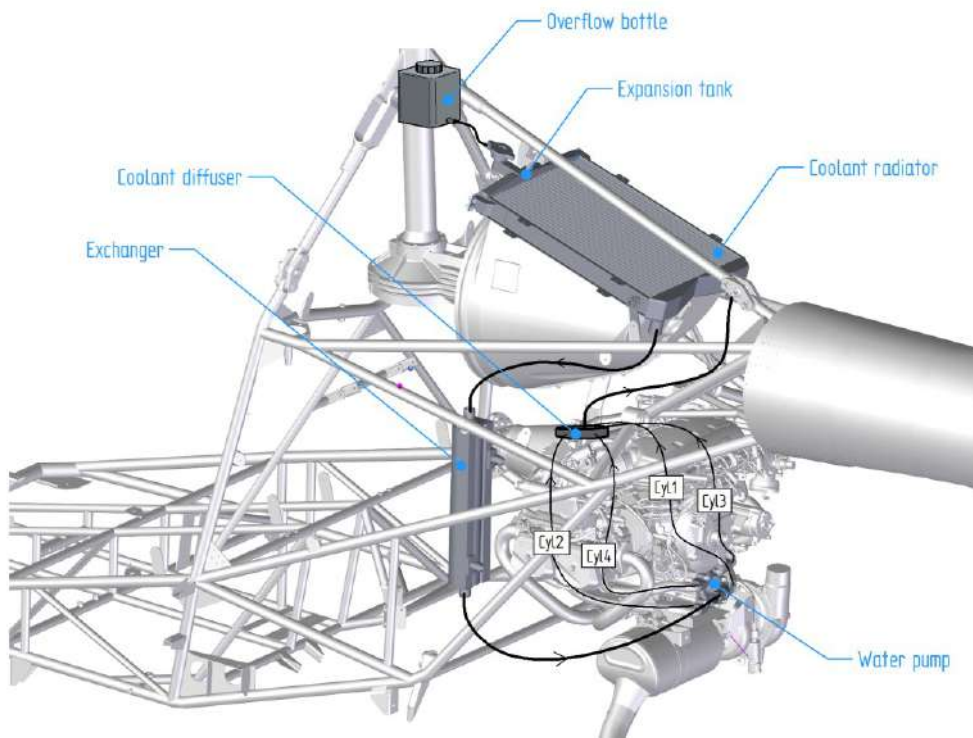

## 1.16 OIL SYSTEM

The lubrication system is designed to ensure cooling and protection of critical components through a continuous cycle. The flow begins at the oil tank, from which the lubricant is sent to the oil-coolant heat exchanger. During this stage, the oil transfers accumulated heat to the coolant before being drawn by the delivery pump, which pressurizes the system allowing internal engine lubrication.

### Installation layout:

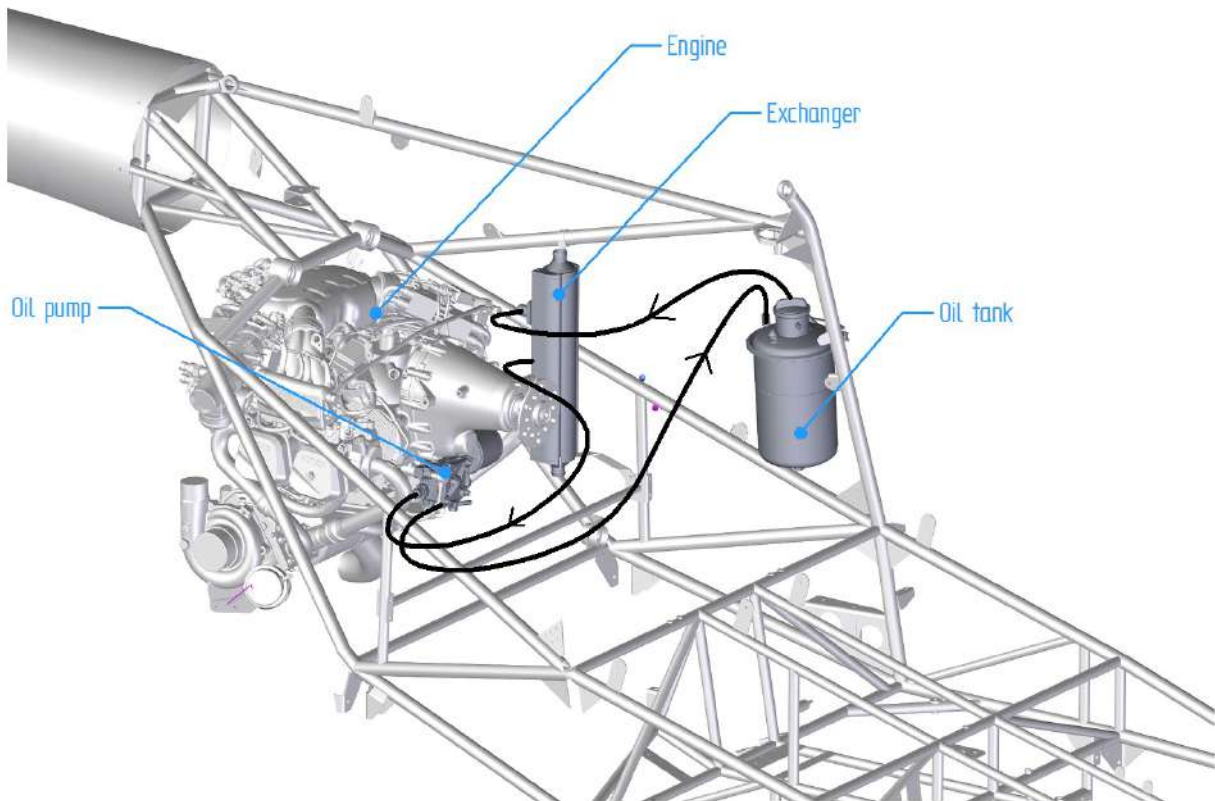

## 1.17 FRAME AND CABIN

The frame is a tubular structure made of titanium alloy. To ensure its structural integrity, the tubes are filled with pressurized air. The nominal pressure is 2 bar. Frame re-pressurization can be carried out through the dedicated valve located on the left side of the structure. In the event of frame damage, air pressure will be lost; this can be detected observing the pressure gauge located next to the CB panel, in front of the left seat.



Due to structure capillarity, it is possible to observe a slow, but constant, decrease of pressure inside the frame, usually during a 20-30 days period. In this situation a reduction of pressure even below the nominal value, is acceptable, because it is not related to a structural damage. On the other hand, a sudden loss of pressure, happened in minutes or seconds, indicates a frame damage. If this happens, refer to the dedicated emergency procedure.

The cockpit is a carbon fiber monocoque, with one door on each side. Each door is equipped with a snap-vent and a storage pocket. The opening and close mechanism is composed by two locking systems, one on the middle of the door and one on the top.

A storage compartment is also located beneath each seat.

## 1.18 LANDING GEAR

The landing gear is of the skid type, designed to deform elastically during landings that are not too heavy. In the event of landings with excessive vertical speed, the deformation becomes permanent, causing the skids to shift upward and outward. This way, the landing gear is able to absorb impact forces without transferring them to the fuselage.

Very small deformations of the skids are acceptable (see maintenance manual for more detailed information).

There is a ground discharge cable in the upper part of the forward left and right legs, beneath the cockpit, connecting the landing gear to the frame.



1.19 CIRCUIT BREAKER PANEL



- 12V	12 Volt auxiliary socket – USB phone charger	5A
-GPS	GPS	3A
-COM	VHF radio	5A
-Nav.STR	Navigation and Strobe lights	5A
-L.L. Trim	Landing Light and Trim actuators	3A
-Clutch	Clutch	3A
- Fint	Fan intercooler ( <i>for future implementation</i> )	2A
- Cab.Ht	Cabin Heating ( <i>for future implementation</i> )	3A
-Trasp.	Transponder	3A
-Panel	Instrument panel (except EMU)	5A
-EMU	Engine Monitor Unit (ECLIPSE NG)	3A
-GOV	Governor	3A

## 1.20 HEAD PANEL

The head panel is located in the cockpit's upper side, between pilots.

The panel switches are located on the forward side of the panel, while the headset connectors, one for each pilot, on the aft side. The utility connected to the switches are all protected by CB's. The utilities are:

- Headset connector
- Cabin heater: optional.
- Intercom switch: enable internal communication between pilots.
- Navigational lights: turn ON or OFF the navigational lights located on both side of the fuselage.
- Landing light: turn ON and OFF the landing light located under the helicopter nose.

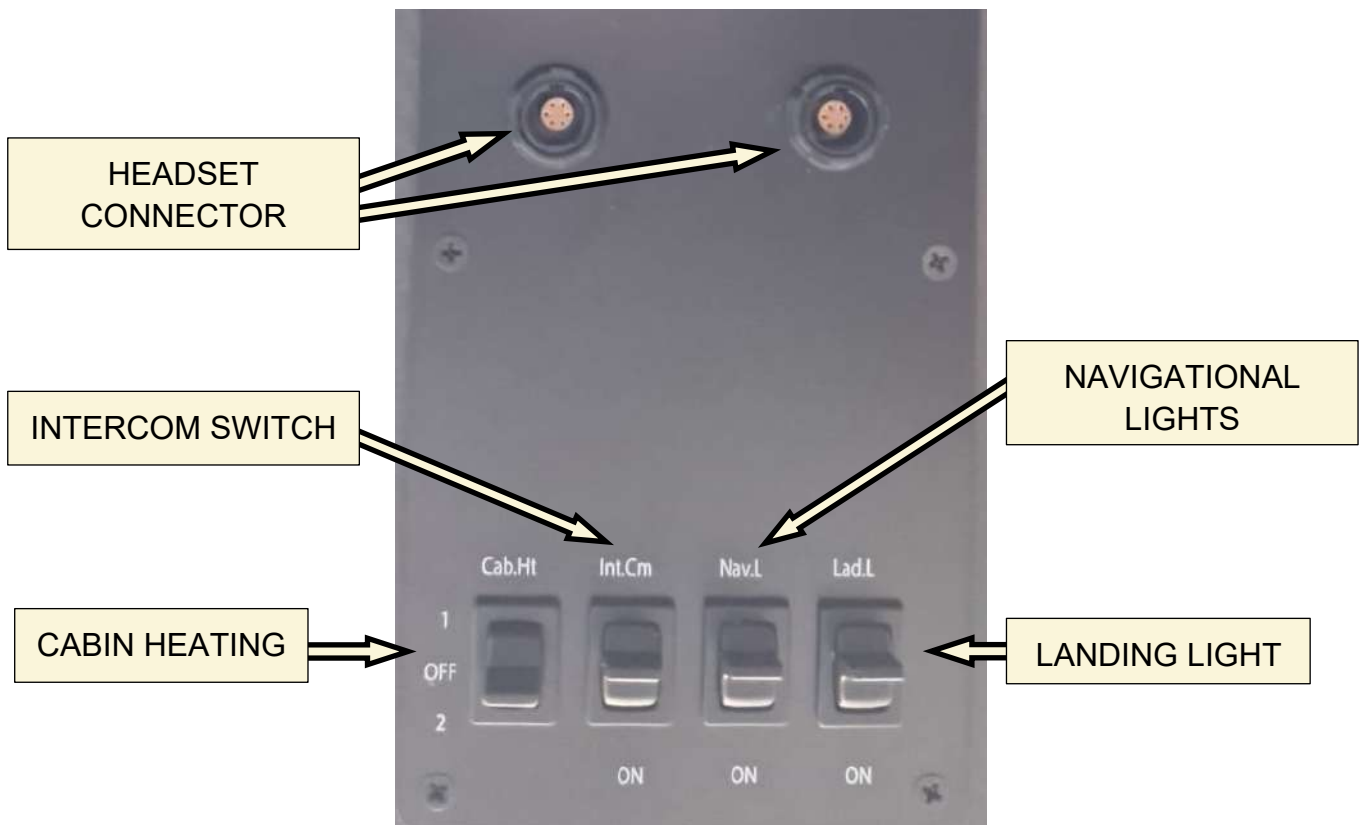

1.21 ALL-ON PANEL

The “All-On-Panel”, located beneath the cockpit instrument panel, is the main control panel for battery, engine and clutch operation.

On the bottom of the panel two arrows, with “ON” and “OFF”, indicate the logical sequence to follow for engine start (ON) and shut down (OFF).

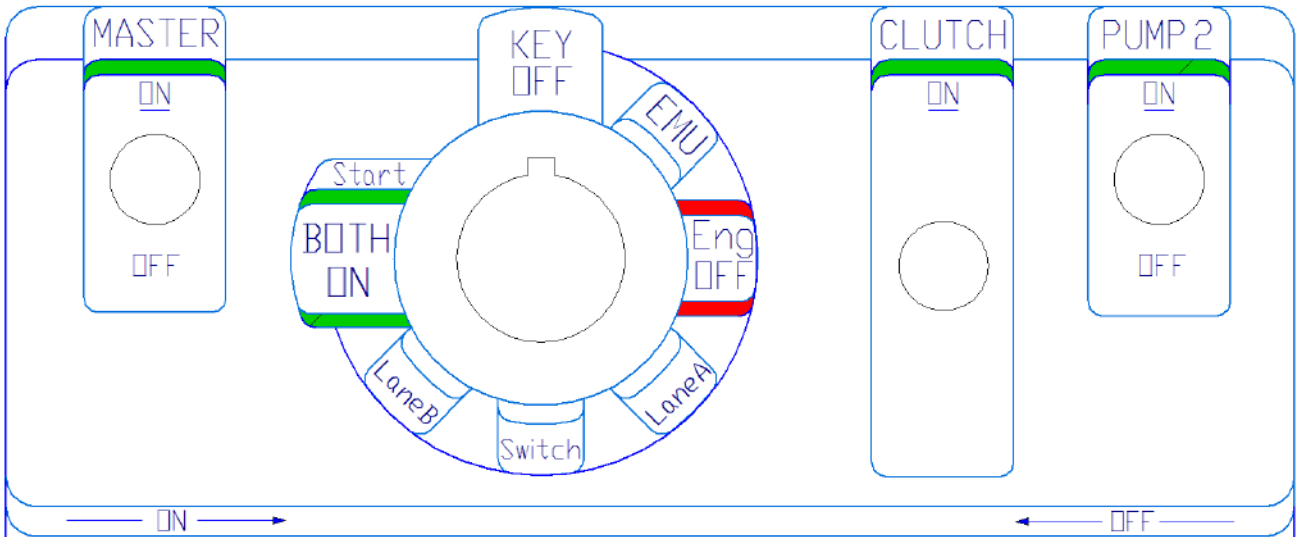

1.21.1 ENGINE KEY SELECTOR

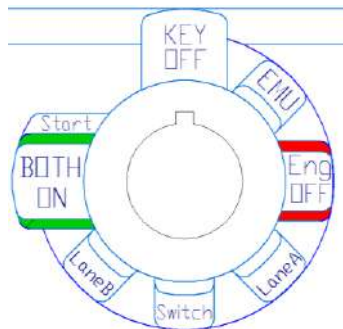

- **KEY OFF:** both “Aircraft” and “EMS” electrical circuits are deactivated, to avoid sparks generation during refueling and ground handling.
- **EMU:** the EMU/SCU is powered. 1 second later, the EMU/SCU activates the Start Power Relay and supplies the ECU with power.
- **Eng OFF:** engine shut down by removing electrical supply. EMU/SCU are still under power.

- **Lane A:** the ECU “Lane A” is activated, and the Fuel Pump 1 is supplied with power and running.
- **Switch:** in this position the ECU switch between “Line A” to “Line B”. Hold this position for at least 1 second every time you pass it.
- **Lane B:** the ECU “Lane B” is activated, the Fuel Pump 2 is supplied with power and running.
- **BOTH ON:** the ECU “Lane A & B” are activated, but only the Fuel Pump 1 is supplied with power. The engine is ready to be started.
- **Start:** backup engine starter is activated. The “Start” position is spring loaded. After starting the engine, maintain in position “BOTH ON”. The Start Power Relay is automatically switched off by the EMU/SCU after 3 seconds that the engine has reached 1500 rpm.

**NOTE:** the “Start” key position is considered a backup to the “Starter” pushbutton on the left collective grip. Refer to the “Engine start” procedure for further details.

#### 1.21.2 ALL-ON PANEL SWITCHES

- **MASTER:** electrical master switch. By selecting ON, before start, the battery is supplying energy to all systems; until replaced by the generators.
- **CLUTCH:** clutch selector. By selecting ON, the electro actuator starts tensioning the clutch belts. CLT light will appear on the warning light bar until the belts are properly tensioned. The switch is guarded to avoid unintentional deselection in flight.
- **PUMP 2:** when ON, the secondary fuel pump is activated.

1.22 SEATS, BAGGAGES AND BALLAST

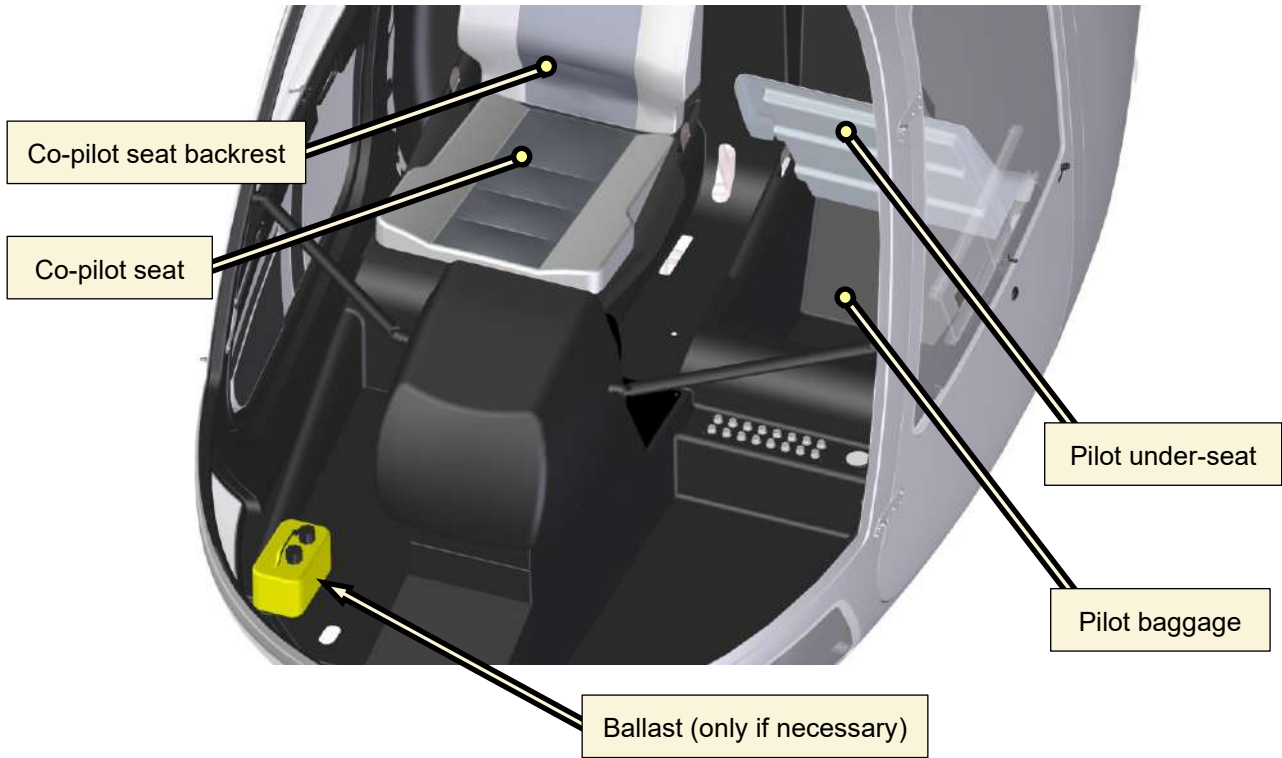

To secure the ballast, use the dedicated knobs provided, screwing them into the designated mounting holes inside the cabin:

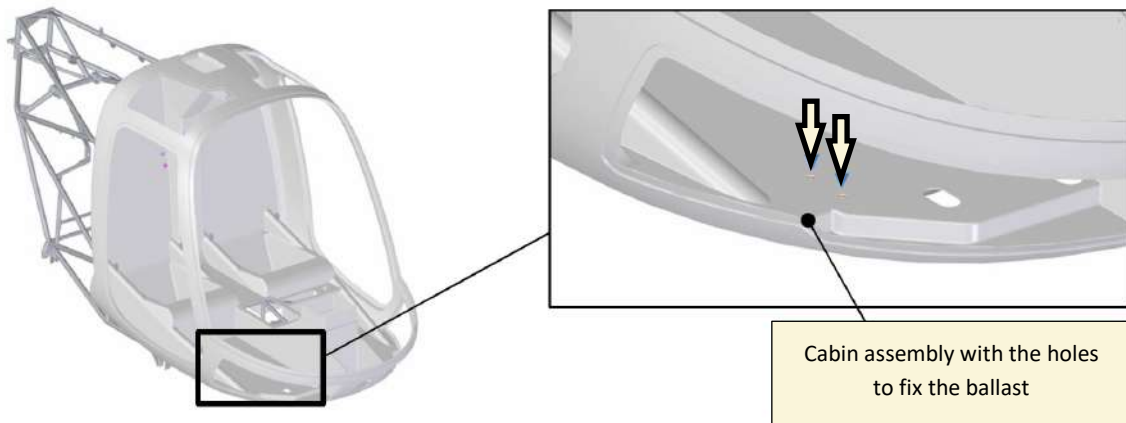

**NOTE**

Ballast shall be used only when required to bring the aircraft centre of gravity within the limits of the weight and balance envelope described in Section 6 (Weight and Balance).

1.23 OIL AND FLUID

Engine lubricant	Use 4-stroke Engine Oil, with additive specific for mechanical gears
	Do not use traditional aviation engine oils without additive
	Use oils with API “SF” or “SG” standards, and “GL4” or “GL5” ratings
Oil Quantity	3.5 l
Oil Consumption	max. 0.1 lt/h
First LH Supply	SHELL ADVANCE ULTRA 15W-50 100% SYNTHETIC

**NOTE:** See Rotax Engine Operators Manual for further details

**OIL TYPE AND QUANTITY:**

.....

<b>Freewheel</b>	GREEN STAR ATF DEXRON II D
Quantity	approx. 35 cc. (as indicated in the manual)

.....

<b>Main Transmission</b>	SWEPCO 201, SAE 90 ISO 220
Quantity	0.9-1.1 l

.....

<b>Tail Transmission</b>	SWEPCO 201, SAE 90 ISO 220
Quantity	70 cc.

.....

<b>Coolant</b>	Demineralized water (60%) + TEXACO Antifreeze/Coolant EGX concentrate (40%)
Quantity	max 3.5 l

## 1.24 STANDARD EQUIPMENT CHARACTERISTICS

<i><b>FLIGHT INSTRUMENTS</b></i>	<i><b>TYPE</b></i>
Altimeter	UMA INSTRUMENTS MODEL N. ALT20MBF-3
Air speed indicator	UMA INSTRUMENTS P/N 16-310-140D
Vertical speed indicator	ECLIPSE
Compass	PAI 700 14V
Hour meter	ECLIPSE
<b>ESCAPE</b>	

<i><b>ENGINE INSTRUMENTS</b></i>	<i><b>TYPE</b></i>
ECLIPSE	ESCAPE SPECIAL ON-BOARD COMPUTER
<i><b>REVE COUNTER</b></i>	
Rev counter rotor/engine	3DA5 – 149-1 DUAL
<b>ESCAPE</b>	

<i><b>OTHER EQUIPMENT</b></i>	<i><b>TYPE</b></i>
Battery	SUPER B 10P - AIRCRAFT
Radio	TRIG
Strobe	LED TYPE
Landing	LED TYPE
<b>ESCAPE</b>	

---

**CONTENTS SECTION 2**

**2 SECTION 2 – LIMITATIONS ..... 56**

2.1 FLIGHT AND MANEUVER LIMITATIONS ..... 56

2.2 COLOR CODE FOR INSTRUMENT MARKINGS ..... 56

2.3 SPEED LIMITS ..... 57

2.4 ROTOR SPEED LIMITS ..... 58

2.5 ENGINE LIMITATIONS ..... 59

**2.5.1 STARTER UNIT CYCLE LIMITATION ..... 59**

2.6 ENGINE INSTRUMENTS INDICATIONS ..... 60

2.7 GENERAL OPERATING TEMPERATURE LIMIT ..... 61

2.8 TYPE OF FUEL ..... 62

2.9 TRANSMISSION LIMITS ..... 63

2.10 WEIGHT LIMITS ..... 64

2.11 CENTER OF GRAVITY (CG) LIMITS ..... 65

2.12 FUEL LIMITATIONS ..... 66

2.13 PLACARDS ..... 67

2.14 TELATEMP (TEMPERATURE RECORDING LABELS) ..... 68

## 2 SECTION 2 – LIMITATIONS

This section specifies operating general limitations for the use of ESCAPE.

### CAUTION

In other chapters additional limitations or prohibitions can be specified. Read carefully.

### 2.1 FLIGHT AND MANEUVER LIMITATIONS

- Aerobatic flights are prohibited.
- Low-G cyclic pushovers are prohibited.
- Maximum crew: 1 pilot + passenger.
- Flight in the rain is prohibited.
- Flight in icing conditions and under snow is prohibited.
- Both seat belts must be buckled.
- Flight when surface wind gust spreads exceed 15 knots is prohibited.
- Respect Centre of Gravity limits.
- Ground maximum gradient allowed for landing: 5°.
- Flight without cowl doors is prohibited
- Water operations are forbidden.

### 2.2 COLOR CODE FOR INSTRUMENT MARKINGS

**RED**

Operating limit. Pointer should not enter red during normal operation.

**YELLOW**

Precautionary or special operating procedure range.

**GREEN**

Normal operating range.

---

## 2.3 SPEED LIMITS

**Air speed limits:**

Never Exceed Airspeed (VNE)	124	MPH
	108	KTS

---

**Airspeed Indications:**

Green range:	0 – 110	MPH
	0 – 96	KTS
Yellow range:	110 – 124	MPH
	96 – 108	KTS
Red line:	124	MPH
	108	KTS

2.4 ROTOR SPEED LIMITS

**Rotor speed limits:**

		Tachometer reading	Actual RPM
Power On	Max	104%	540
	Min	96%	480
Transient 5 min:		110%	571
Power Off	Max	110%	571
	Min	90%	467

**Rotor RPM indications:**

Upper red line	110%
Yellow range	105% to 110%
Green range	96% to 104%
Yellow range	90% to 95%
Lower red line	90%

2.5 ENGINE LIMITATIONS

**Manifold pressure limits (MAP):**

Normal operating range	Map 0 – 42	inHg	Continuous
Maximum Continuous (MCP)	Map 42	inHg	Continuous
Maximum	Map 42-51	inHg	Max 5 min

**Engine RPM limits:**

Engine: Rotax 915 iS

Idle	1800 RPM	-	Continuous
Minimum	4900 RPM	96 %	Continuous
Maximum Continuous (MCP)	5500 RPM	104 %	Continuous
Rpm limits	5800 RPM	110 %	Max 5 min

**NOTE:** See ROTAX Engine manual.

2.5.1 STARTER UNIT CYCLE LIMITATION

Start ON	10 sec
Start OFF	2 min

## 2.6 ENGINE INSTRUMENTS INDICATIONS

### Exhaust Gas Temperature (EGT)

Normal	900°C	1652°F
Max	950°C	1742°F
Coolant Temperature (CT)	Max 120°C	248°F

### Oil Temperature:

Max	130°C	266°F
Min	50°C	120°F

### Manifold Temperature:

Normal	50 °C	122°F
Max	80°C	176°F

### Outside Air Temperature (OAT)

Max	35°C	95°F
Min	-10°C	14°F

### Oil Pressure

Min	2 bar	29 PSI
Max	7 bar	101.5 PSI
Normal	2.0-5.0 bar	29-72.5 PSI

**NOTE:** See ROTAX Engine manual.

## 2.7 GENERAL OPERATING TEMPERATURE LIMIT

**Outside Air Temperature (OAT)**

Max	35 °C	95 °F
Min	-10 °C	14 °F

## 2.8 TYPE OF FUEL

**Fuel** Super or Unleaded gasoline for car

Octane rating is not lower than MON 85 o RON 95 (preferably unleaded)

100 LL grade Aviation Fuel

## 2.9 TRANSMISSION LIMITS

### Oli Temperature

Normal	50° - 88°C	122-190°F
Max	100°C	122°F



## 2.11 CENTER OF GRAVITY (CG) LIMITS

For loading procedure and C.G. limitations, refer to section 6.

## 2.12 FUEL LIMITATIONS

Super fuel octane rating is not lower than MON 83 or RON 90.

100LL grade Aviation Fuel can be used (for detailed instructions contact the authorized workshop).

**Total tank capacity:** 65/90 liters

**Usable tank capacity:** 60/85 liters

**Low fuel caution light (LWF):** when it turns on, the engine will run out of fuel in 20 minutes.

**2.13 PLACARDS****NO SMOKING**

In front of the pilot.

**ATTENTION****AUTOMOTIVE FUEL****UNLEADED OR AVGAS 100LL****CAPACITY 65/90 LT (17.1/23.7 US gal)** Near fuel tank filler cap.**FUEL TANK****SHUT-OFF VALVE**

Near Fuel Valve.

**MAXIMUM CAPACITY****11Lbs – 5Kg**

Inside baggage compartment under the seat.

**CHECK LOAD AND CENTERING****MINIMUM WEIGHT 176 Lbs – 80 Kg** In front of the pilot.**FRICITION COLLECTIVE**

In clear view of the pilot on the collective stick.

**FRICITION CYCLIC**

On the central tunnel near the cyclic friction knob.

**LOW G PUSHOVER PROHIBITED**

On the central tunnel.

---

## 2.14 TELATEMP (TEMPERATURE RECORDING LABELS)

**MGB TEMPERATURE**

Normal 88°C (190°F) - Max 100°C (212°F)

Indicates possible malfunctions or damages at the MGB.

**SWASHPLATE BEARINGS**

Normal 77°C (170°F) - Max 82°C (180°F)

Indicates possible malfunction or damage of the bearings.

**MAST**

Max 82°C (180°F)

Indicates possible malfunction or damage of the bearings.

**TGB TEMP**

Normal 77°C (170°F) - Max 82°C (180°F)

Indicates possible malfunction or damage at the TGB.

**CLUTCH**

Engine axis bearing.

Normal 80°C (176°F) - Max 120°C (248°F)

Indicates possible malfunction or damages of the bearing.

**BATTERY**

Max 55°C (131°F)

Indicates possible malfunction or damage

2.15 SAFE LOAD FACTOR

Safe positive load factor (g)	+3.5 g
Safe negative load factor (g)	-1.0 g

---

**CONTENTS SECTION 3**

**3 SECTION 3 – NORMAL PROCEDURES ..... 71**

3.1 EXTERNAL CHECKS ..... 71

3.2 PRE-FLIGHT CHECKS ..... 72

3.3 CHECK LIST ..... 77

3.4 ALTERNATIVE ENGINE START ..... 83

3.5 TAKE-OFF PROCEDURE ..... 84

3.6 APPROACH AND LANDING ..... 85

3.7 SPEED FOR SAFETY FUNCTIONING ..... 86

3.8 NOISE ABATEMENT ..... 87

3.9 HOVERING ..... 88

### 3 SECTION 3 – NORMAL PROCEDURES

#### 3.1 EXTERNAL CHECKS

- Light conditions must be suitable for visual checks, if necessary, use adequate light sources.
- Before moving the aircraft, drain the fuel line.
- Clean main rotor blades, verify the condition of the edges and of the trim tabs. Verify the main rotor pitch change connecting rods free play (normally there is no play or very small play).
- Clean frontal windshield inside and outside.
- Clean tail rotor blades, verify conditions of the connecting rods free play (normally there is no play or very small play).
- Open cowling doors.
- Check and eventually clean air scoops and engine air filter.

### 3.2 PRE-FLIGHT CHECKS

#### **ZONE 1 – LEFT CENTRAL**

- Drain the fuel tank sump through the dedicated drain valve.
- Verify oil level, if necessary fill up to 5mm above max level mark.
- Check oil circuit pipes, condition and leaks.
- Check cooling liquid level.
- Check the correct fastening of electric connections, Televel, clutch, engine probe plugs and governor.
- Check the condition and freedom of the governor system control.
- Check condition and freedom of the cyclic kinematic system control.
- Check the condition and freedom of the collective kinematic system control.
- Check MGB, condition and leaks.
- Verify MGB Telatemps.
- Check Telatemp of engine/clutch bearings.
- Check the conditions of the clutch.
- Check cleanness of prints and absence of foreign object on the vee-belts.
- Check the condition and cleanness of the engine cooling fan.
- Check the condition and cleanness of the radiator's cooling fan.
- Check the integrity of the Thomas joint.
- Check the condition and leaks in the freewheel area.

#### **ZONE 2 – TAIL BOOM FASTENING**

- Verify condition, fastening and leaks in cooling circuit pipes.
- Check the condition and leaks in fuel system.
- Check the entirety of the engine mounting.
- Check tail boom fixing points.
- Check dents and deformations, rivets conditions of the tail boom.

**ZONE 3 – TAIL TRANSMISSION**

- Check condition, structural integrity and correct fastening of the vertical empennage.
- Check condition, structural integrity and correct fastening of the horizontal stabilizer.
- Check the condition and structural integrity of the tailskid.
- Check the condition, leaks and oil level of the TGB.
- Verify Telatemp indications.
- Check the kinematic system of tail rotor pitch change control.
- Check conditions and structural integrity of the rotor head and of the blades fixing system.
- Check the condition and wear of the tail rotor blades.
- Verify freedom in movements of the pitch change.
- Check structural integrity and correct fastening of tail rotor blades ,
- Check status ventilation hole in the tail rotor blades,

**ZONE 4 - TAIL BOOM ATTACHMENT**

- Verify conditions, fixing and leaks of the cooling circuit pipes.
- Check the conditions and leaks of the fuel system.
- Check the entire engine mount.
- Check tail boom attachments.
- Check dents and deformations of tail boom, check condition of the rivets.
- Check engine ground cables.
- Check the conditions and leaks of the turbine area.
- Check air box – intercooler connections.
- Check the conditions and cleanness of the intercooler.
- Verify cleanness of the engine air filter.
- Check engine electric connections (ECU).

- Check the conditions and leaks of the MGB.
- Verify MBG oil level.
- Check conditions and oil leaks of the upper pulley.
- Check the conditions and correct fixing of the lower pulley.
- Verify conditions of the vee-belts.
- Check the clutch system.
- Check the conditions and leaks of the tank.
- Check the fuel level.
- Drain the GASCOLATOR.
- Check landing gear legs.
- Check conditions, fixing, leaks and cleanness of radiators.

#### **ZONE 5 – ROTOR HEAD**

- Check conditions, correct fixing and cleanness of the swashplate system.
- Check conditions and correct fixing of the rotor head system.
- Check conditions and correct fixing of the blades fixing plates.
- Check the abrasion conditions of the main rotor blades.
- Check the conditions of the trim tab.

#### **ZONE 6 – RIGHT FRONT**

- Check the door general condition and window integrity.
- Verify absence of loose or unnecessary objects in the cabin.
- If passenger not present, fasten the seatbelts and lock the under seat.

#### **ZONE 7 - FRONT**

- Check the entirety of anterior windscreen.
- Check Pitot tube.

**ZONE 8 – LEFT FRONT**

- Check the door general condition and window integrity.
- Verify frame pressure.
- Verify breakers insertion.
- Verify absence of loose or unnecessary objects in the cabin.
- Verify flight controls frictions insertion.

**NOTE**

Any technical discrepancy identified during the pre-flight check must be recorded in the Helicopter Logbook, including a description of the corrective action taken, the date, and the total helicopter flight hours at the time of the intervention.

Further details in section 7.

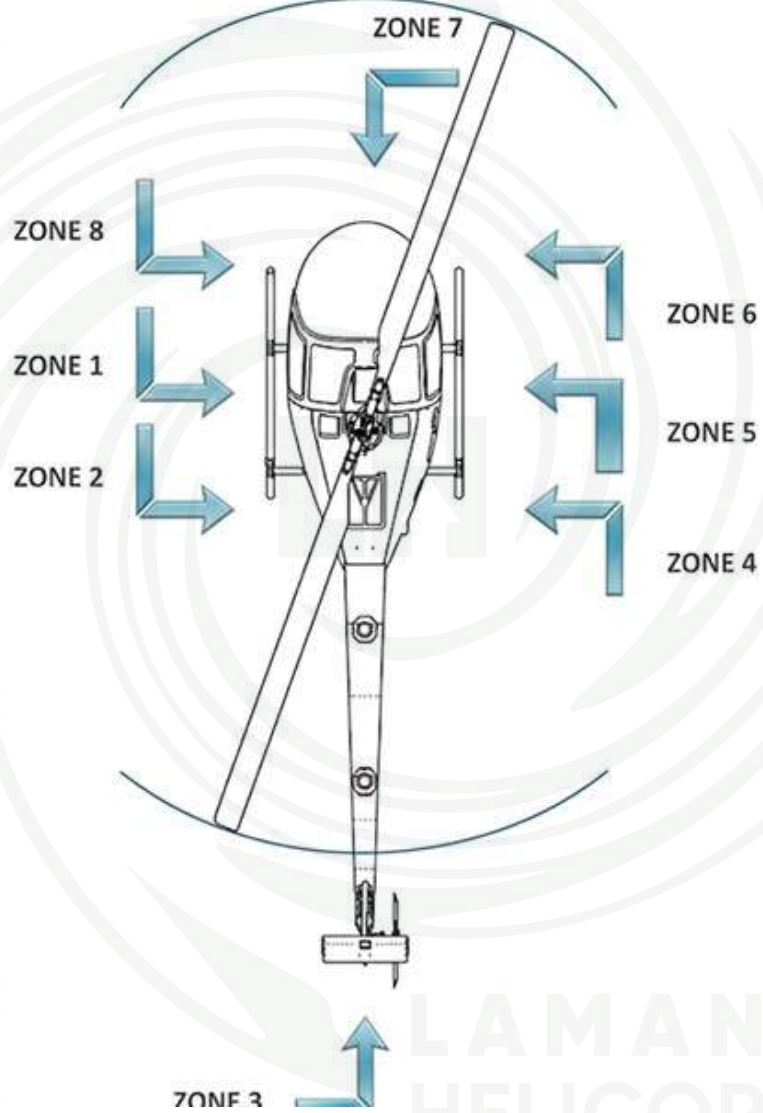

---

### 3.3 CHECK LIST

## BEFORE STARTING

Balance limits	Checked
Right and left door	Closed, safety pin inserted, upper door lock inserted
Seat belts	Fastened
Fuel shutt-off valve	ON
Fuel level	Check
Cyclic/collective friction	OFF
Cyclic/Collective/Pedals	Full travel free
Collective	Full down, friction on
Cyclic	Neutral, friction on
Pedals	Centered
All switches	OFF
Frame pressure gauge	Check
Breakers	In
Throttle position	IDLE

### CAUTION

Passenger seat belts must be fastened in his absence.

Secure and lock the passenger seat when not in use.

## ENGINE START

<b>MASTER</b> switch	- <b>ON</b>
<b>ENGINE KEY</b>	- <b>EMU</b> wait a few second
--	- <b>Lane A</b>
Grip Throttle %	- 41 Cold – 38 Hot
Area	- Clear
<b>COLLECTIVE BUTTON START</b>	- Start (engine run)
<b>CLUTCH</b> Swicth	- <b>ON</b>
	-Check engine parameter
	-Wait for the rotor engagement
Clutch light	- Wait for Off
<b>ENGINE KEY</b>	- <b>Line A</b> (check parameter)
	- <b>Switch</b>
--	- <b>Line B</b> (check FP1 led Off)
--	- <b>BOTH ON</b> (FP1 On - FP2- Off)
<b>PUMP 2</b> Switch	- <b>ON</b> (FP2 On)
GEN EMU indication	- OK
Engine/Rotor RPM	- 50 % 2.500 RPM
Engine Oil	- Temp. 40°C
Set Engine/Rotor RPM gradually, without stopping in the intermediate zone.	- 80%
Engine Oil	- Temp. 50°C
Engine/Rotor RPM	- 100 %
Throttle	- Close rapidly
Freewheel disengagement	- Check
Minimum Engine RPM	- Not lower than 2.000 RPM

## ALL ON PANEL CHECK

**ALL ON PANEL** before flight check all switch and key position,  
all of them must be in **ON** position:

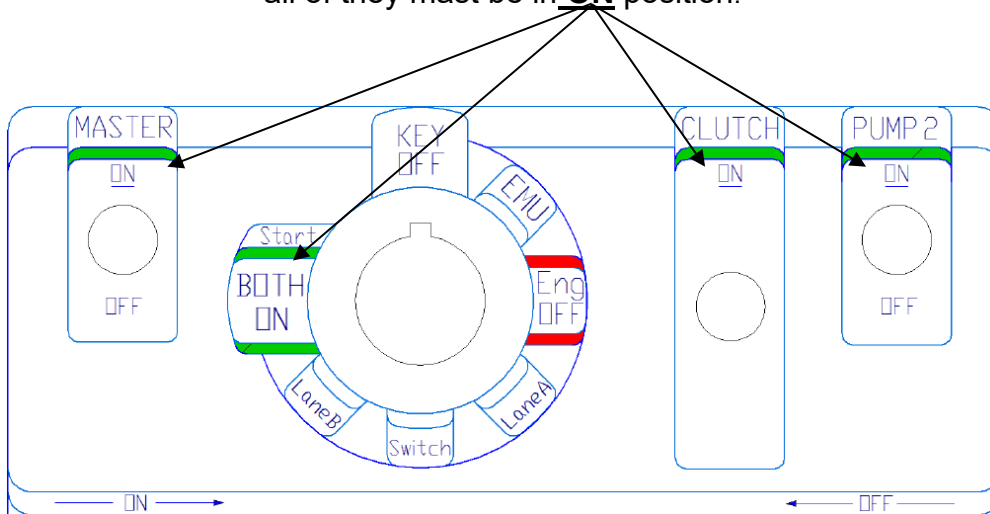

To turn Engine ON and enable the helicopter on fly, follow the direction of the arrow ON, this arrow indicates the sequence to follow to put the switches in the ON position, from left to right

- |             |               |
|-------------|---------------|
| 1 Master ON | 2 Key BOTH ON |
| 3 Clutch ON | 4 Pump 2 ON   |

---

## PRE-FLIGHT CHECK

Doors	- Check closing
Fuel shut-off valve	- Check On
ALL ON Frontal Panel	- All switches On
EMU parameter	- All green
Altimeter	- set QFE
Radio	- On, well-functioning
OAT	- Check temperature
Electromagnetic fuses	- All On
Warning/caution lights test	- push Test button
Cyclic/Collective	- frictions Off
Engine/Rotor RPM	- 80%
Governor	- On
Engine/Rotor RPM	- 104%

**CLEAR AEREA**

**TAKE-OFF**

---

## ENGINE SHUT OFF

Collective	- Completely down
Governor	- Off
Engine/Rotor RPM	- 90% check temp. OIL/CHT
Trim	- Neutral position
Cyclic/Collective friction	- On
Engine/Rotor RPM	- 90% wait temperature OIL/CHT about 100°C
Throttle	- IDLE
<b>PUMP 2</b>	- <b>Off</b>
<b>CLUTCH</b>	- <b>Disengage</b> (few second GOV light On)
<b>ENGINE KEY</b>	- <b>ENGINE OFF</b>
	- KEY OFF
Clutch led light	- Wait for Off
Radio	- Off
<b>MASTER</b>	- <b>Off</b>

### CAUTION

Do not slow rotor by using collective during shutdown. Blades may hit the tail boom.

## ALL ON PANEL CHECK

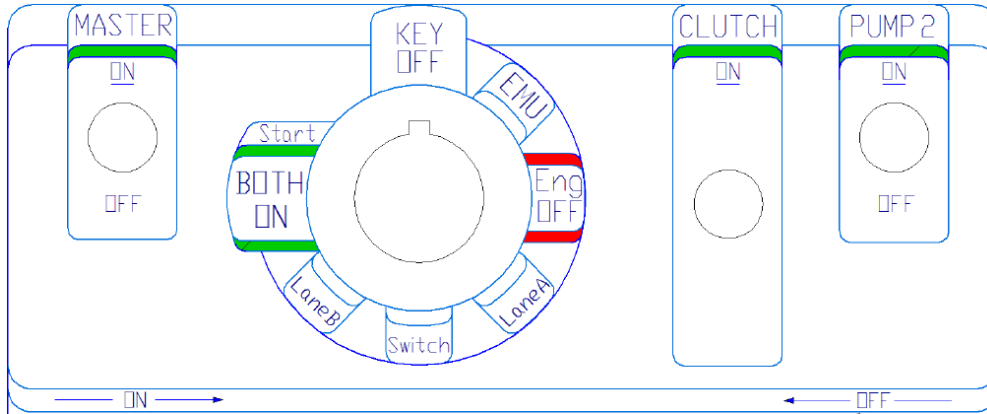

To turn off Engine and disable the helicopter on fly, follow the direction of the arrow OFF, this arrow indicates the sequence to follow to put the switches in the OFF position, from right to left

- |                  |              |
|------------------|--------------|
| 1 Pump 2 OFF     | 2 Clutch OFF |
| 3 Key Engine OFF | 4 Master OFF |

### 3.4 ALTERNATIVE ENGINE START

In case of malfunction of the collective “Starter” pushbutton, the following alternate starting procedure can be executed:

<b>MASTER</b> switch	- <b>ON</b>
<b>ENGINE KEY</b>	- <b>EMU</b> wait a few second
--	- <b>Lane A</b>
--	- <b>Switch</b>
--	- <b>Line B</b> (check FP1 led Off)
--	- <b>BOTH ON</b> (FP1 On - FP2- Off)
--	- <b>Start</b>

**NOTA:** Only switch on one fuel pump when starting the engine. Switching on both fuel pumps can lead to a bad start behavior.

**NOTA:** Activate starter for maximum of 10 consecutive seconds only, followed by a cooldown period of 2 minutes.

<b>CLUTCH</b>	- <b>ON</b> (wait CLT light OFF)
<b>PUMP 2</b>	- <b>ON</b>
<b>Start procedure</b>	- <b>continue as described in normal “Engine start” procedure.</b>

### 3.5 TAKE-OFF PROCEDURE

#### TAKE-OFF

- 1) Slowly raise the collective stick and eventually help the governor with the throttle to keep RPM at 104% and bring the aircraft in hovering.
- 2) Push the cyclic forward, lift the collective until gaining climb speed, following diagram High-speed (HV) as shown in section 5.6. Keep rotor speed in the upper part of the green arch during take-off and climb.

#### NOTE

Take-off performance data and procedures have been established based on tests conducted on both paved (asphalt) and unpaved (grass/earth) surfaces.  
Climb speed: refer to Chapter 3.7 (Speed for safety functioning).

### 3.6 APPROACH AND LANDING

#### **APPROACHING**

- 1) Rotor RPM at 104%. The indicator of engine RPM must be in the green arch. Make final approach into wind, starting with landing speed of 50MPH (43 KTS). Rotor RPM at 104%.
- 2) Reduce air speed and altitude to hover. (Be sure rate of descent is less than 300 ft/min before air speed is reduced below 23MPH (20 KTS)).

#### **LANDING**

- 1) From hovering, lower collective gradually until ground contact.
- 2) After initial ground contact, lower collective to full down position.

#### **CAUTION**

When landing on a slope, set cyclic control in neutral position before complete reduction of the collective.

#### **NOTE**

Approach and landing performance data and procedures have been established based on tests conducted on both paved (asphalt) and unpaved (grass/earth) surfaces. Approach and descent speeds: refer to Chapter 3.7 (Speed for safety functioning).

---

**3.7 SPEED FOR SAFETY FUNCTIONING****SPEED (IAS)**

	<b>MPH</b>	<b>KTS</b>
<b>BEST TAKE OFF &amp; CLIMB</b>	50	43
<b>BEST RATE OF CLIMB (Vy)</b>	50	43
<b>BEST APPROACH SPEED</b>	50	43
<b>BEST GLIDE SPEED IN AUTOROTATION</b>	50	43
<b>BEST CRUISE SPEED</b>	80	70
<b>BEST MANEUVER SPEED</b>	70	61

### 3.8 NOISE ABATEMENT

To improve the quality of our environment and to dissuade overly restrictive ordinances against helicopter use, it is imperative that every pilot minimizes noise irritation to the public.

**The following are several techniques which should be employed when possible:**

- 1) Avoid flying over concerts, sport meetings or other outdoor assemblies of people.
- 2) If it is not possible to fly high, preferably over 700 ft AGL, avoid blade slaps. Blade slaps usually occur during shallow high-speed descents, especially during turns. It can be avoided by using steeper descendants. With the left door removed, the pilot can easily determine those flight conditions which produce blade slap and develop piloting techniques to eliminate or reduce it.
- 3) When departing or approaching a landing site, avoid prolonged low flights close to residential districts, hospitals, schools and other noise-sensitive areas.
- 4) Fly always above 500 ft AGL and preferably above 900 ft AGL.
- 5) Repetitive noise is far more irritating than a single occurrence. If you must fly over the same area more than once, vary your flight path to not overfly the same settlements each time.

### 3.9 HOVERING

During hovering, with summer temperature conditions, monitor all parameters regarding functioning of engine/transmission, with close attention to the Manifold temperature. If the MAX OPERATIVE LIMIT is reached, leave immediately hovering position and drive the helicopter into shifted flight, so that the intercooler will decrease Manifold temperature.

---

**CONTENTS SECTION 4**

<b>4</b>	<b>SECTION 4 – EMERGENCY PROCEDURES .....</b>	<b>91</b>
4.1	DEFINITIONS: .....	91
4.2	EMERGENCY LIGHTS .....	92
4.3	ENGINE FAILURE AND MALFUNCTIONS .....	94
4.3.1	ENGINE FAILURE – FLIGHT / AUTOROTATION .....	95
4.3.2	EMERGENCY DESCENT .....	96
4.3.3	ENGINE FAILURE - HIGH HOVER .....	96
4.3.4	ENGINE FAILURE - LOW HOVER.....	96
4.3.5	AIR RESTART PROCEDURE .....	96
4.3.6	EMERGENCY ENGINE SHUT DOWN - GROUND.....	97
4.3.7	EMERGENCY ENGINE SHUT DOWN – FLIGHT .....	97
4.3.8	THROTTLE CABLE DISCONNECTION.....	97
4.3.9	GOVERNOR FAILURE .....	97
4.3.10	LOW NR .....	98
4.3.11	HIGH NR.....	98
4.3.12	ENGINE OVERHEATING.....	98
4.4	EMERGENCY EXIT .....	99
4.4.1	EMERGENCY DOOR OPENING FROM OUTSIDE .....	99
4.5	FUEL SYSTEM .....	100
4.5.1	LOW FUEL .....	100
4.5.2	FUEL PRESSURE HIGH.....	100
4.5.3	FUEL PRESSURE LOW .....	100
4.5.4	FUEL PUMP 1 FAIL .....	101
4.5.5	FUEL PUMP 2 FAIL .....	101
4.6	ELECTRICAL FAILURES.....	102
4.6.1	SINGLE GENERATOR FAILURE.....	102
4.6.2	DOUBLE GENERATOR FAILURE.....	102
4.7	FIRE EMERGENCYES .....	103
4.7.1	ENGINE FIRE - FLIGHT.....	103
4.7.2	FIRE DURING ENGINE START - GROUND .....	103
4.7.3	ELECTRICAL FIRE/SMOKE - GROUND .....	103
4.7.4	ELECTRICAL FIRE/SMOKE - FLIGHT .....	103
4.8	CLUTCH FAILURE .....	105
4.9	TRANSMISSION MALFUNCTIONS.....	106
4.9.1	MAIN ROTOR CONTROLS BINDING .....	106
4.9.2	MAIN/TAIL GEAR BOX CHIP.....	106
4.9.3	MAIN GEAR BOX OIL TEMPERATURE HIGH .....	106

---

4.10	TAIL ROTOR FAILURE .....	108
4.10.1	TAIL ROTOR DRIVE FAILURE – LOW HOVER .....	108
4.10.2	TAIL ROTOR DRIVE FAILURE – FLIGHT / HIGH HOVER.....	108
4.10.3	TAIL ROTOR CONTROL SYSTEM FAILURE – LOW HOVER.....	109
4.10.4	TAIL ROTOR CONTROL SYSTEM FAILURE – FLIGHT / HIGH HOVER.....	109
4.10.5	TAIL ROTOR CONTROL BINDING – LOW HOVER .....	110
4.10.6	TAIL ROTOR CONTROL BINDING – FLIGHT / HIGH HOVER .....	110

## 4 SECTION 4 – EMERGENCY PROCEDURES

### 4.1 DEFINITIONS:

This section contains the procedures that should be adopted in the event of an emergency or malfunction of the devices or systems installed on board the helicopter. The decision whether or not to follow the instructions provided herein must be the result of an overall assessment of the flight situation encountered. Therefore, it is the pilot's responsibility to apply the appropriate procedure; however, the pilot also has the authority to deviate from it if deemed necessary to ensure a higher level of safety. Where possible, the procedures are based on the indications made available to the pilot by the flight instruments.

**Land Immediately:** Land at once, even if for example this means ditching or landing in trees. The consequences of continued flight are likely to be more hazardous than those of landing at a site normally considered unsuitable.

**Land as soon as possible:** Do not continue flight for longer than is necessary to achieve a safe and unhurried landing at the nearest site.

**Land as soon as practical:** Land at the nearest aviation location or, if there is none reasonably close, at a safe landing site selected for subsequent convenience.

**Continue flight:** The resulted flight condition allows an appropriate safety margin, that can be maintained without an excessive pilot workload. It is pilot responsibility to decide whether to continue the flight or not, and to what extent.

## 4.2 EMERGENCY LIGHTS

### LIGHTS COLORS:

<b>WHITE:</b>	Systems status
<b>YELLOW:</b>	Cautionary light, indicating system malfunction.
<b>RED:</b>	Warning lights, indicating severe malfunction or system degradation

### **CAUTION**

Takeoff with a red light on is forbidden.

### ADVISORY LIGHTS PANNEL LIGHTS:

#### **-LWF (RED)**

#### **LOW FUEL.**

When on, indicates approximately 15 liters of usable fuel remaining.

### **CAUTION**

Do not use LOW FUEL light as an indicator of fuel quantity.

#### **-MCP (YELLOW)**

#### **Main gear box chip detector.**

Indicates presence of metallic particles in the lubricating oil; due to a possible damage of the internal gearing.

#### **-TCP (YELLOW)**

#### **Tail gear box chip detector.**

Indicates presence of metallic particles in the lubricating oil; due to a possible damage of the internal gearing.

#### **-FP1 (RED)**

#### **FUEL PUMP 1**

Fuel pump n.1 has lost electrical supply.

#### **-FP2 (RED)**

#### **FUEL PUMP 2**

Fuel pump n.1 has lost electrical supply.

### **CAUTION**

It is forbidden to take-off with FP1 or FP2 inoperative.

#### **-GOV (WHITE)**

#### **GOVERNOR**

When on indicates that engine RPM throttles governor is off.

**-CLT (RED)****CLUTCH**

Indicates clutch actuator is on, either engaging or disengaging clutch.

**-BBS (YELLOW)****BACK-UP BATTERY SWITCH**

Illuminates when the BBS, located on the collective, has been activated.

**ECLIPSE ALARM INDICATIONS:****-GEN 1****ENGINE GENERATOR 1**

The light comes when GEN1 has a malfunction or a failure, not providing electrical power.

**-GEN 2****ENGINE GENERATOR 2**

The light comes when GEN2 has a malfunction or a failure, not providing electrical power.

**CAUTION**

The ECLIPSE instrument may, in some cases, display a false alarm. Unless positive indication of the displayed malfunction has been identified, before performing any corrective actions carry out a quick reset of the indication.

**ECLIPSE alarm reset procedure:**

Press the 4th button from the left on the instrument or 3th button on the cyclic control panel.

If, after this operation, the alarm indication is not confirmed, continue the flight. If the alarm appears again, apply the prescribed corrective procedure.

### 4.3 ENGINE FAILURE AND MALFUNCTIONS

An engine failure is indicated by a sudden loss of power, followed by secondary effects like change of noise, right yaw and NR decay.

The good outcome of an engine failure is mostly related to pilot ability to recognize the condition and enter in autorotational regime with no delay, avoiding NR to decrease below the minimum value.

Engine power reduction, on the other hand, can be associated to different factors (es. fuel ignition system, ECU,...) that might allow minimum flight capability; or not. It is pilot responsibility to understand the actual flight profile and conditions, in order to apply the correct procedure.

#### **WARNING**

If the flight is performed inside the envelope highlighted H-V diagram, a safe autorotational profile might not be achieved, so a safe landing is not guaranteed.

#### 4.3.1 ENGINE FAILURE – FLIGHT / AUTOROTATION

##### **CAUTION**

When lowering the collective the helicopter C.G. will move forward, causing a pitch down moment. Apply aft cyclic accordingly to control the attitude.

- |                 |  |
|-----------------|--|
| 1) Collective   | DOWN   |
| 2) NR           | 90% to 110%  |
| 3) Speed        | 50 MPH / 43 KTS<br>(best glide and min. sink)                                    |
| 4) Landing area | IDENTIFY (preferably into the wind or, if over water, facing the incoming waves) |

*If conditions permit and no engine malfunctions are suspected.*

- |                          |         |
|--------------------------|---------|
| 5) Air Restart Procedure | EXECUTE |
|--------------------------|---------|

*If conditions does not permit the engine restart.*

- |                 |   |
|-----------------|---|
| 6) Head panel   | ALL OFF   |
| 7) Radio        | MAYDAY broadcast  |
| 8) At 40 ft AGL | FLARE max 10° pitch up, maintain NR within limits and reduce forward speed as much as possible. |
| 9) At 8 ft AGL  | LEVEL attitude and cushion the landing, minimizing any lateral movements.                       |

##### **CAUTION**

Do not apply backward cyclic during ground/water contact to prevent possible blade strike with the tail boom.

- |                     |   |
|---------------------|---|
| 10) On ground/water | GROUND EMERGENCY SHUT DOWN (over water, the use of collective to slow down the main rotor, will cause the helicopter to yaw right, facilitating the capsized) |
| 11) Emergency exit  | EXECUTE   |

##### **WARNING**

After ditching there is a very high probability that the helicopter will capsize. Familiarity with the underwater emergency egress procedure is mandatory if flight over water is intended.

---

#### 4.3.2 EMERGENCY DESCENT

An emergency descent is a maneuver that imply a high rate of descent while the engine is still running. The magnitude of the flight parameters is at pilot discretion.

Comparable with an autorotation, this maneuver can, if associated to certain malfunctions or emergencies, evolve in a full autorotation. For this reason, the same principles use to enter in autorotation can be applied to the emergency descent.

---

#### 4.3.3 ENGINE FAILURE - HIGH HOVER

- |               |                       |
|---------------|-----------------------|
| 1) Collective | DOWN to maintain NR   |
| 2) Cyclic     | FORWARD to gain speed |

#### **CAUTION**

The best glide speed of 50 mph (43 KTS) might not be achievable. In this case achieve the highest speed possible based on the flight condition.

- |                             |         |
|-----------------------------|---------|
| 3) Engine Failure in Flight | EXECUTE |
|-----------------------------|---------|
- 

#### 4.3.4 ENGINE FAILURE - LOW HOVER

- |                               |  |
|-------------------------------|--|
| 1) Pedal                      | LEFT to minimize the yaw                       |
| 2) Cyclic                     | MAINTAIN POSITION minimizing lateral movements |
| 3) Collective                 | CUSHON the landing                             |
| 4) Ground Emergency Shut Down | EXECUTE  |
- 

#### 4.3.5 AIR RESTART PROCEDURE

#### **CAUTION**

Restart the engine in flight only after a stable autorotation condition has been achieved.

- |                             |                              |
|-----------------------------|------------------------------|
| 1) BBS                      | ON                           |
| 2) Throttle                 | SOFT IDLE (36%)              |
| 3) Coll. starter pushbutton | PRESS (monitor engine start) |
| 4) Engine                   | CHECK ON-LINE                |
| 5) Throttle                 | OPEN (80%)                   |
| 6) NR                       | RECOVER (green arch)         |
-

---

**NOTE:** In case of collective starter pushbutton malfunction, is possible to use the key selector position “start” on the “All-On-Panel”.

**CAUTION**

Do not attempt to restart the engine if a malfunction is suspected.

---

4.3.6 EMERGENCY ENGINE SHUT DOWN - GROUND

- |                        |          |
|------------------------|----------|
| 1) Fuel shut-off valve | CLOSED   |
| 2) Engine Key Selector | ENG. OFF |
| 3) Master              | OFF      |
- 

4.3.7 EMERGENCY ENGINE SHUT DOWN – FLIGHT

- |                        |          |
|------------------------|----------|
| 1) Fuel shut-off valve | CLOSED   |
| 2) Engine Key Selector | ENG. OFF |
- 

4.3.8 THROTTLE CABLE DISCONNECTION

The cable connecting the collective throttle grip to the engine throttle lever has disconnected or broken. The engine will stabilize at its minimum RPM with a noticeable power reduction.

- |                 |         |
|-----------------|---------|
| 1) Autorotation | EXECUTE |
|-----------------|---------|
- 

4.3.9 GOVERNOR FAILURE

Governor is sending erroneous input to the engine throttle lever.

**WARNING**

A governor failure or malfunction can cause an abrupt increase or decrease of engine RPM, with direct effect on the NR.

- |                             |                         |
|-----------------------------|-------------------------|
| 1) Collective throttle grip | STOP any unwanted input |
| 2) NR                       | CONTROL manually        |
| 3) GOV switch               | OFF                     |
| 4) Continue flight          |                         |
-

#### 4.3.10 LOW NR

NR below 94% + acoustic alarm

1) Collective

REDUCE to recover NR

---

#### 4.3.11 HIGH NR

NR below 108% + acoustic alarm

2) Collective

INCREASE to recover NR

---

#### 4.3.12 ENGINE OVERHEATING

Indication of high oil (OIL) or water coolant (CT) temperatures is displayed:

1) Power

REDUCE (as soon as operational conditions permit)

1) Speed

80 MPH / 70 KTS (to increase ventilation)

*If temperature return inside normal value*

2) **Land as soon as practicable**

*If temperature remains high*

3) **Land as soon as possible**

*If unusual engine noises or behaviors are perceived*

4) **Land immediately**

---

#### 4.4 EMERGENCY EXIT

##### **WARNING**

Exit the helicopter only when the airframe and the main rotor blades have stopped.

- |                      |                 |
|----------------------|-----------------|
| 1) Controls friction | ENGAGE          |
| 2) Doors             | UNLOCK and OPEN |
| 3) Headset           | REMOVED         |
| 4) Seat belts        | UNFASTENED      |
| 5) Aircraft          | EVAQUATE        |

##### **WARNING**

Direction of evacuation should be, if possible, toward the frontal sector of the airframe, to avoid risks of injuries with the tail structure and rotor.

---

#### 4.4.1 EMERGENCY DOOR OPENING FROM OUTSIDE

##### **WARNING**

Approaching the helicopter must be initiated only when the airframe and the main rotor blades have stopped, or the scenario is considered to be safe.

- |                       |                         |
|-----------------------|-------------------------|
| 1) Central window pin | PULL UP                 |
| 2) Door handle        | SLIDE and open the door |

##### **NOTE**

Ensure the area around the door is clear before opening

##### **WARNING**

Be aware of the main rotor blades, as they can cause injury or death if still in motion.

---

---

## 4.5 FUEL SYSTEM

### 4.5.1 LOW FUEL

LWF light illuminates on the ALP when fuel contents is below 15 liters. Flight endurance is about 20 minutes in cruise condition.

1) **Land as soon as practicable**

*If fuel leakage is suspected, a fire in the engine compartment might happens*

2) **Land as soon as possible**

---

### 4.5.2 FUEL PRESSURE HIGH

High fuel pressure, above 3,5 bar, can be identify only on the ECLIPSE display.

1) PUMP 2 OFF

1) **Land as soon as practicable**

**CAUTION**

Be aware that engine performance might be affected, based on operational conditions.

---

### 4.5.3 FUEL PRESSURE LOW

Low fuel pressure, below 2,5 bar (max 3 sec), can be identify only on the ECLIPSE display.

1) PUMP 2 CHECK ON

2) **Land as soon as practicable**

**CAUTION**

Be aware that engine performance might be affected, based on operational conditions.

---

---

#### 4.5.4 FUEL PUMP 1 FAIL

FP1 light illuminates on the ALP when the fuel pump has lost the electrical supply.

- 1) Fuel pressure CHECK

*If within limits*

- 2) **Land as soon as practicable**

**NOTE**

The remaining fuel pump is capable to meet the fuel requirement for normal engine operation

*If outside limits*

- 3) **Land as soon as possible**

**CAUTION**

Be aware that engine performance might be affected, based on operational conditions.

---

#### 4.5.5 FUEL PUMP 2 FAIL

FP2 light illuminates on the ALP when the fuel pump has lost the electrical supply.

- 1) PUMP 2 CHECK ON / RESET
- 2) Fuel pressure CHECK

*If within limits*

- 4) **Land as soon as practicable**

**NOTE**

The remaining fuel pump is capable to meet the fuel requirement for normal engine operation

*If outside limits*

- 5) **Land as soon as possible**

**CAUTION**

Be aware that engine performance might be affected, based on operational conditions.

---

#### 4.6 ELECTRICAL FAILURES

Electrical failures can be identified thanks to the ALP or the Eclipse. The failure of one generator will imply that the battery supply power to all the utilities, except the engine related ones, and it is not kept charged. In case of double generator failure, the battery is the sole provider of electrical power to both utilities and engine.

##### 4.6.1 SINGLE GENERATOR FAILURE

- 3) BBS ON
- 4) Head Panel switches ALL OFF
- 5) **Land as soon as practicable**

**CAUTION**

Battery is powering all the utilities and it is not being charged by the remaining generator.

**NOTE:** A fully efficient battery allows a flight endurance of approximately 1 hour.

##### 4.6.2 DOUBLE GENERATOR FAILURE

**WARNING**

With double generator failure the engine will shut down.

- 1) Collective DOWN (achieve stable autorotation)
- 2) Landing spot IDENTIFY (possibly with head wind)
- 3) Emergency landing EXECUTE

*If altitude and condition permits*

- 6) Air restart procedure EXECUTE
- 7) Head Panel switches ALL OFF

*If the engine restart has been successful and condition permits*

- 8) Safe flight profile ACHIVE
- 9) **Land as soon as practicable** (A fully efficient battery could maintain full operating autonomy for at least 10 minutes)

---

## 4.7 FIRE EMERGENCIES

### 4.7.1 ENGINE FIRE - FLIGHT

- |                      |  |
|----------------------|--|
| 1) Emergency descent | INITIATE   |
| 2) Windows air vent  | OPEN facing forward  |
| 3) Landing area      | IDENTIFY (preferably into the wind or, if over water, facing the incoming waves) |

*If close to the ground/water and engine still running*

- |            |   |
|------------|---|
| 4) Landing | PERFORM (consider a possible power reduction) |
|------------|---|

*If the has engine stopped running*

- |                 |         |
|-----------------|---------|
| 5) Autorotation | EXECUTE |
|-----------------|---------|
- 

### 4.7.2 FIRE DURING ENGINE START - GROUND

A fire during the engine start procedure can be detected by smell of burning fuel/oil or visual clue.

- |                                 |         |
|---------------------------------|---------|
| 1) Emergency Shut Down - Ground | EXECUTE |
| 2) Emergency Exit               | EXECUTE |
- 

### 4.7.3 ELECTRICAL FIRE/SMOKE - GROUND

An electrical fire is indicated by a smell of burning insulation and/or acrid smoke.

- |                                 |         |
|---------------------------------|---------|
| 1) Emergency Shut Down - Ground | EXECUTE |
| 2) Emergency Exit               | EXECUTE |
- 

### 4.7.4 ELECTRICAL FIRE/SMOKE - FLIGHT

An electrical fire is indicated by a smell of burning insulation and/or acrid smoke. The most important consideration is to maintain safe flight conditions while investigating the cause.

---

Unless the source of the smoke or fire can be identified (visible equipment malfunctions or CB panel) and the equipment electrically isolated, carry out the following procedure.

- 1) Airspeed REDUCE (recommended 50 MPH  
/ 43 KTS)
- 2) Windows air vents OPEN (both if possible)

*If operational conditions permit*

- 3) **Land immediately**

*If time available*

- 4) Head panel switches ALL OFF

*If the fire or smoke cleared*

- 5) **Land as soon as possible**

*If the fire or smoke does not clear*

- 6) **Land immediately**
-

#### 4.8 CLUTCH FAILURE

CLT light stays illuminated for more than 3 second, meaning that a proper tension of the transmission belts has not been achieved or a failure of the actuator. A mismatch between engine RPM and NR might be experience.

- |                        |                      |
|------------------------|----------------------|
| 1) CLT circuit breaker | PULL (yellow collar) |
| 2) NR                  | 95% - 104%           |

**NOTE:** When the clutch CB is deactivated, the clutch actuator locks its position to the one it had at the moment of deactivation.

- |                                    |                 |
|------------------------------------|-----------------|
| 3) Flight controls                 | MINIMIZE inputs |
| 4) <b>Land as soon as possible</b> |                 |

*If further indications of transmission malfunction appears or NR becomes difficult to maintain*

- |                 |         |
|-----------------|---------|
| 5) Autorotation | EXECUTE |
|-----------------|---------|
-

---

## 4.9 TRANSMISSION MALFUNCTIONS

A transmission malfunction may be indicated by an unusual noise, vibrations or seizure of the flight controls. Attention should be given on the analysis of the situation compared to the actual flight conditions.

### 4.9.1 MAIN ROTOR CONTROLS BINDING

If a binding of the main rotor controls line happens, based on the severity of the binding, a greater effort might be required to move the controls (cyclic and/or collective). Control range authority might be restricted, as well as the low speed flight envelope.

**Land as soon as possible** using a combination of power and speed to maintain helicopter attitude.

If binding occurred during hover, land vertically.

---

### 4.9.2 MAIN/TAIL GEAR BOX CHIP

Illumination of caution lights MCP or TCP indicates presence of metallic particles inside the relative transmission oil lubricating system.

- |                                    |   |
|------------------------------------|---|
| 1) Power                           | REDUCE (as soon as operational conditions permit) |
| 2) Speed                           | 50 MPH / 43 KTS (Vy)                              |
| 3) <b>Land as soon as possible</b> |   |

*If unusual vibrations, sounds or other indications coming from the main/tail transmission are perceived*

- |                            |  |
|----------------------------|--|
| 4) <b>Land immediately</b> |  |
|----------------------------|--|

---

### 4.9.3 MAIN GEAR BOX OIL TEMPERATURE HIGH

Indication of MGB oil temperature above 100°C displayed on the ECLIPSE transmission page.

- |                                       |   |
|---------------------------------------|---|
| 1) Power                              | REDUCE (as soon as operational conditions permit) |
| 2) Speed                              | 50 MPH / 43 KTS (Vy)                              |
| 3) <b>Land as soon as practicable</b> |   |

*If temperature remains high*

**4) Land as soon as possible**

*If unusual vibrations, sounds or other indications coming from the main transmission are perceived*

**5) Land immediately**

---

#### 4.10 TAIL ROTOR FAILURE

Three type of tail rotor failure exists:

- **Drive failure:** total loss of tail rotor trust. The helicopter yaws violently and at high rate to the left, causing also pitching and rolling moments. Pedals are free but ineffective. This condition can cause pilot disorientation, that's why immediate action shall be taken. A drive failure might be anticipated by vibrations coming from the tail.
- **Control system failure:** a mechanical problem happens along the control line, leaving the pedals free but ineffective or partially effective. The helicopter may yaw left or right, based on pedal position.
- **Control binding:** the pedal control line is jammed in the last position and tail rotor control is not more possible. Do not apply full force on the pedals, to avoid further damage of the control line.

##### 4.10.1 TAIL ROTOR DRIVE FAILURE – LOW HOVER

- |                          |  |
|--------------------------|--|
| 1) Collective + throttle | REDUCE + HARD IDLE                               |
| 2) Cyclic                | maintain attitude and minimize lateral movements |
| 3) Collective            | CUSHON the landing                               |
| 4) Engine                | OFF (if time permits)                            |

##### 4.10.2 TAIL ROTOR DRIVE FAILURE – FLIGHT / HIGH HOVER

- |                                  |   |
|----------------------------------|---|
| 1) Collective                    | REDUCE immediately to control yaw               |
| 2) Speed/Roll/Power              | find a combination to maintain aircraft control |
| 3) Landing site                  | IDENTIFY  |
| <i>When in condition to land</i> |   |
| 4) Engine                        | OFF   |
| 5) Autorotation                  | EXECUTE   |

**NOTE:** Raising or lowering the collective while maintaining the NR within limits, may be helpful in controlling the sideslip; increasing collective the nose goes to the left, and vice versa.

---

**4.10.3 TAIL ROTOR CONTROL SYSTEM FAILURE – LOW HOVER**

- |                          |  |
|--------------------------|--|
| 1) Collective + throttle | REDUCE + HARD IDLE                               |
| 2) Cyclic                | maintain attitude and minimize lateral movements |
| 3) Collective            | CUSHON the landing                               |
| 4) Engine                | OFF (if time permits)                            |
- 

**4.10.4 TAIL ROTOR CONTROL SYSTEM FAILURE – FLIGHT / HIGH HOVER**

- |                     |   |
|---------------------|---|
| 1) Speed/Roll/Power | find a combination to maintain aircraft control |
| 2) Right pedal      | PRESS gently and progressively                  |

*If POSITIVE right pedal response is achieved (even at full displacement)*

Use the available pedal control margin to execute a safe landing. Because low speed envelope might be restricted; consideration should be given for a slide landing.

*If NEGATIVE right pedal response is achieved (even at full displacement)*

- |               |   |
|---------------|---|
| 3) Collective | REDUCE achieve a descent rate to align the nose to the flight path.   |
| 4) Landing    | As speed reduce, nose might start to yaw to the left. In this case a low speed rotating landing will be required. |
| 5) Throttle   | HARD IDLE before touch down to minimize yaw movements   |
| 6) Collective | CUSHION landing applying smooth and progressive input.  |
| 7) Engine     | OFF   |

4.10.5 TAIL ROTOR CONTROL BINDING – LOW HOVER

- |                                    |  |
|------------------------------------|--|
| 5) Collective                      | REDUCE   |
| 6) Cyclic                          | maintain attitude and minimize lateral movements |
| 7) <b>Land as soon as possible</b> |  |
| 8) Engine                          | OFF only if severe left yaw occurs.              |

**NOTE:** In this condition a safer landing can be achieved under powered flight, rather than by shutting down the engine.

4.10.6 TAIL ROTOR CONTROL BINDING – FLIGHT / HIGH HOVER

- |   |   |
|---|---|
| 1) Speed/Roll/Power                               | find a combination to maintain aircraft control   |
| <i>If RIGHT pedal in (high tail rotor thrust)</i> |   |
| 2) Approach                                       | Steep low speed (high power) with nose to the right of the flight path.   |
| 3) Landing  | Use power/speed combination to keep nose aligned.   |
| 4) Engine   | OFF   |
| <i>If LEFT pedal in (low tail rotor thrust)</i>   |   |
| 5) Approach                                       | Normal approach (low power) with nose to the right of the flight path, if possible.                               |
| 6) Landing  | As speed reduce, nose might start to yaw to the left. In this case a low speed rotating landing will be required. |
| 7) Throttle                                       | HARD IDLE before touch down to minimize yaw movements   |
| 8) Collective                                     | CUSHION landing applying smooth and progressive input.  |
| 9) Engine   | OFF   |

**WARNING**

Premature airspeed reduction to low values may result in loss of directional control when increasing collective.

---

**CONTENTS SECTION 5**

<b>5</b>	<b>SECTION 5 – PERFORMANCE .....</b>	<b>113</b>
5.1	INTRODUCTION .....	113
5.2	AIRSPEED CALIBRATION CURVE .....	114
5.3	DENSITY ALTITUDE CHART .....	115
5.4	IGE HOVER CEILING VS. MAXIMUM WEIGHT .....	116
5.5	OGE HOVER CEILING VS. MAXIMUM WEIGHT .....	117
5.6	H-V DIAGRAM .....	118
5.7	AUTOROTATION PERFORMANCE .....	119
5.8	CLIMB PERFORMANCE .....	121
5.9	ENGINE PERFORMANCE .....	122

## 5 SECTION 5 – PERFORMANCE

### 5.1 INTRODUCTION

Hover controllability has been demonstrated up to 17 MPH (15 KTS) wind from any direction up to 8000 ft (2500 m) density altitude.

Refer to IGE Hover ceiling performance data for allowable maximum take-off weight.

#### **CAUTION**

The performance data presented in this section has been obtained under ideal conditions and with NR at 104%.

Performance under other conditions may be substantially less.

5.2 AIRSPEED CALIBRATION CURVE

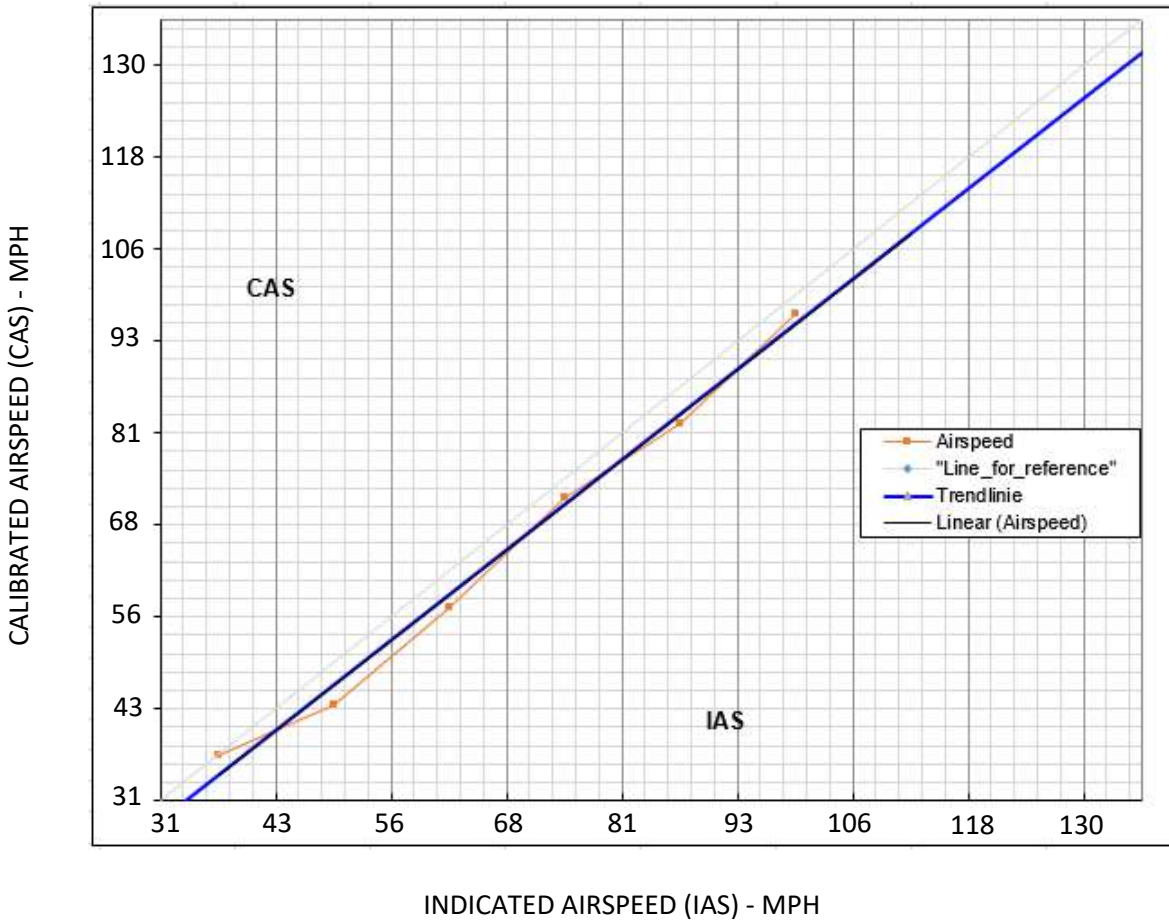

5.3 DENSITY ALTITUDE CHART

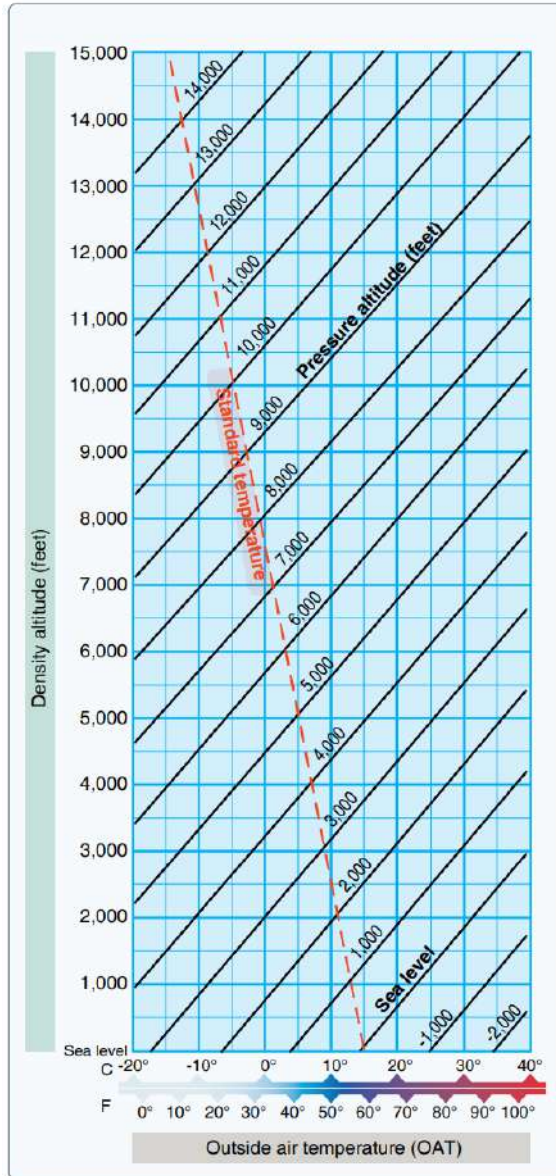

5.4 IGE HOVER CEILING VS. MAXIMUM WEIGHT

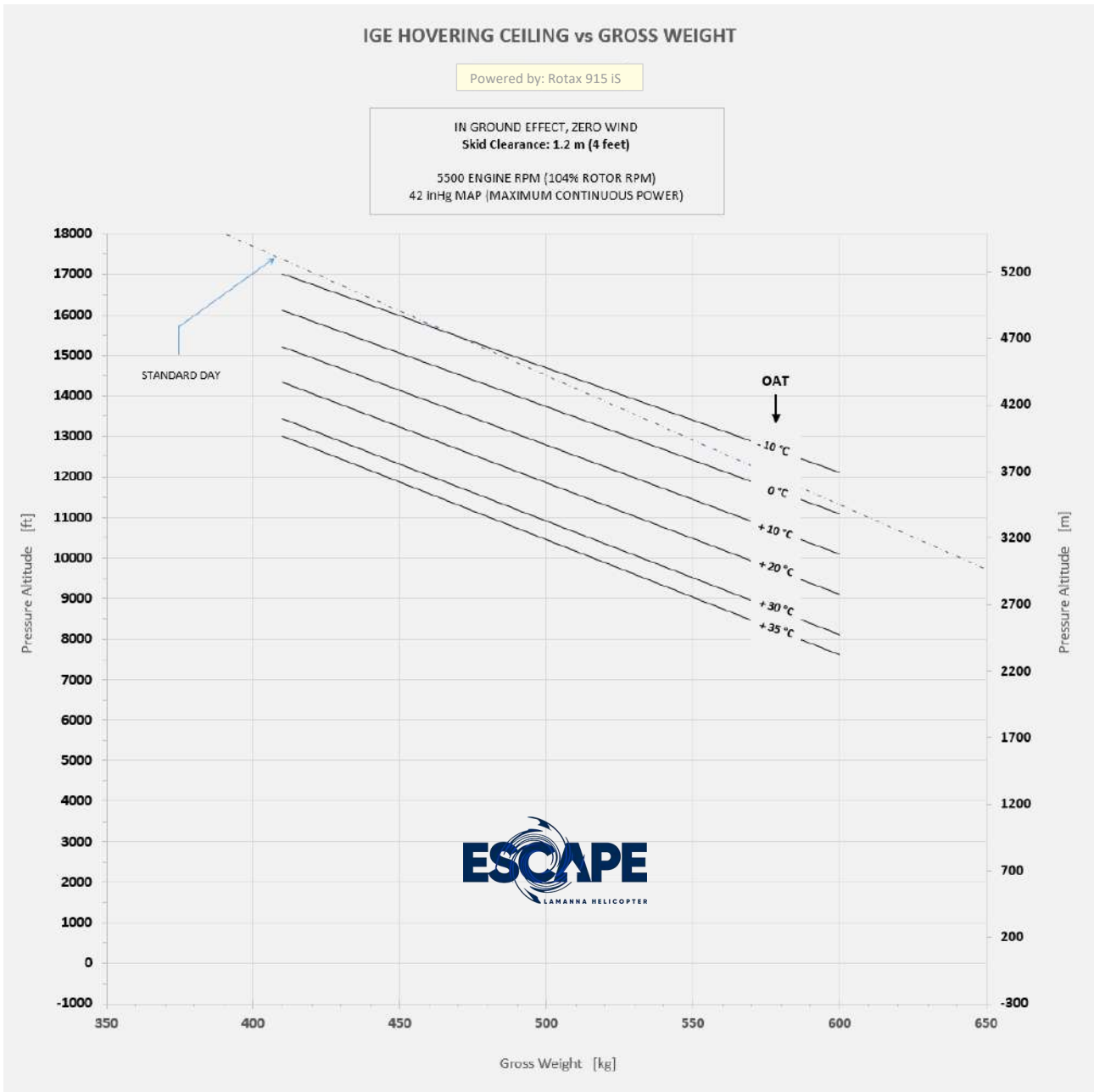

5.5 OGE HOVER CEILING VS. MAXIMUM WEIGHT

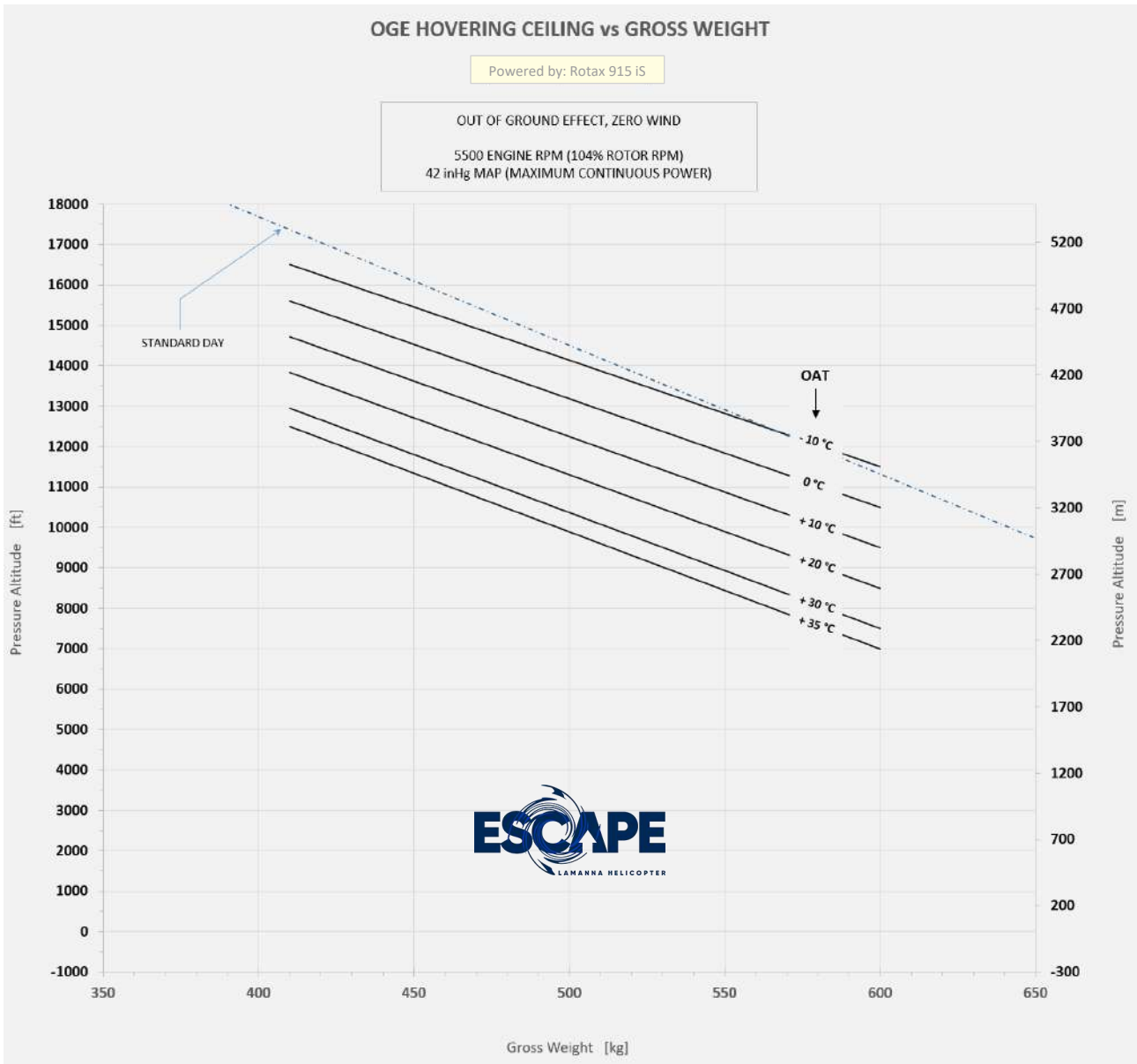

5.6 H-V DIAGRAM

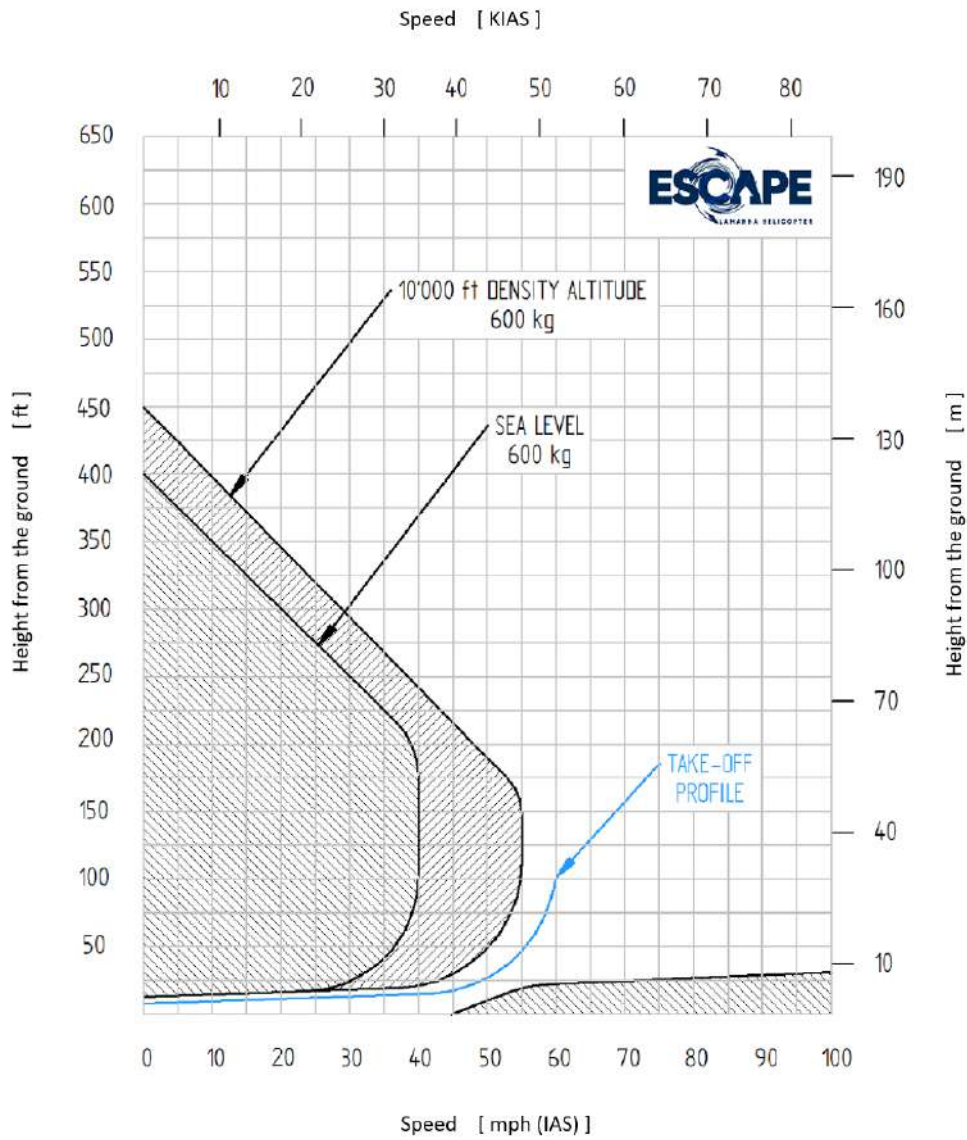

5.7 AUTOROTATION PERFORMANCE

Based on experimental flight tests, the following speeds are established for emergency power-off management:

Speed for minimum rate of descent (min. sink)	50 MPH (43 KTS)
Speed for maximum glide distance (best glide)	50 MPH (43 KTS)
Rotor speed (N <sub>R</sub> )	100 %
Rate of descent:	1350 ft/min (approx. 6.85 m/s)
Best glide ratio (3260 ft distance / 1000 ft altitude)	3.26:1

**NOTE**

The performance declared data are established for maximum take-off weight (MTOM) under ISA conditions at Sea Level with zero wind.

Rate of descent vs. Pressure altitude and temperature at **MTOW** condition:

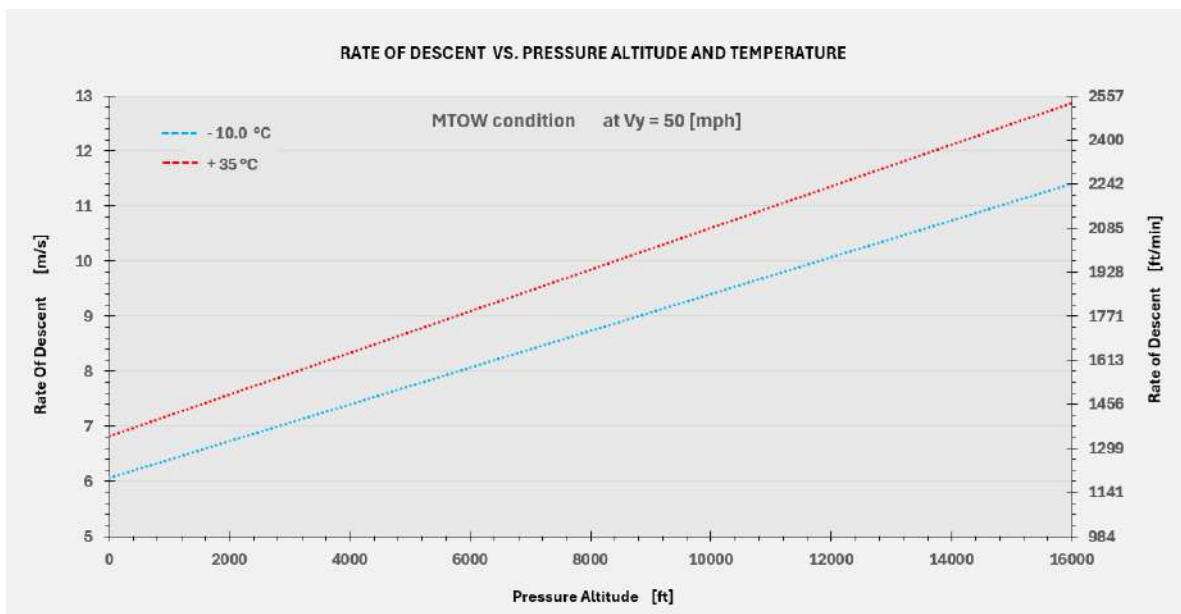

Rate of descent vs. Pressure altitude and temperature at **MinTOW** condition:

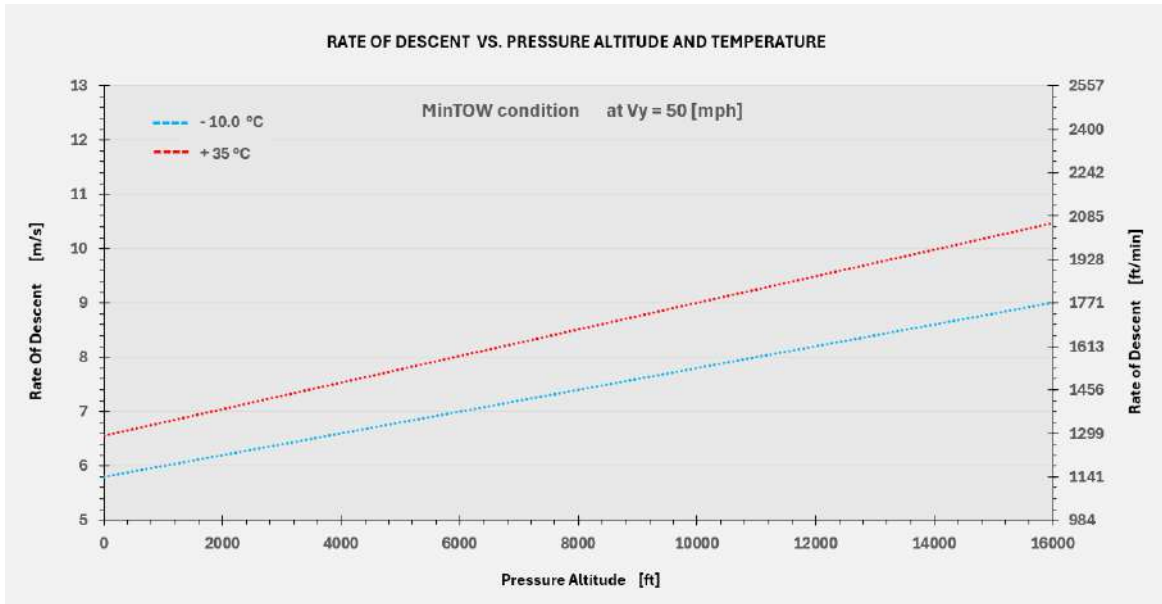

5.8 CLIMB PERFORMANCE

Speed for maximum rate of climb

50 MPH (43 KTS)

Rate of climb vs. Pressure altitude and temperature at **MTOW** condition:

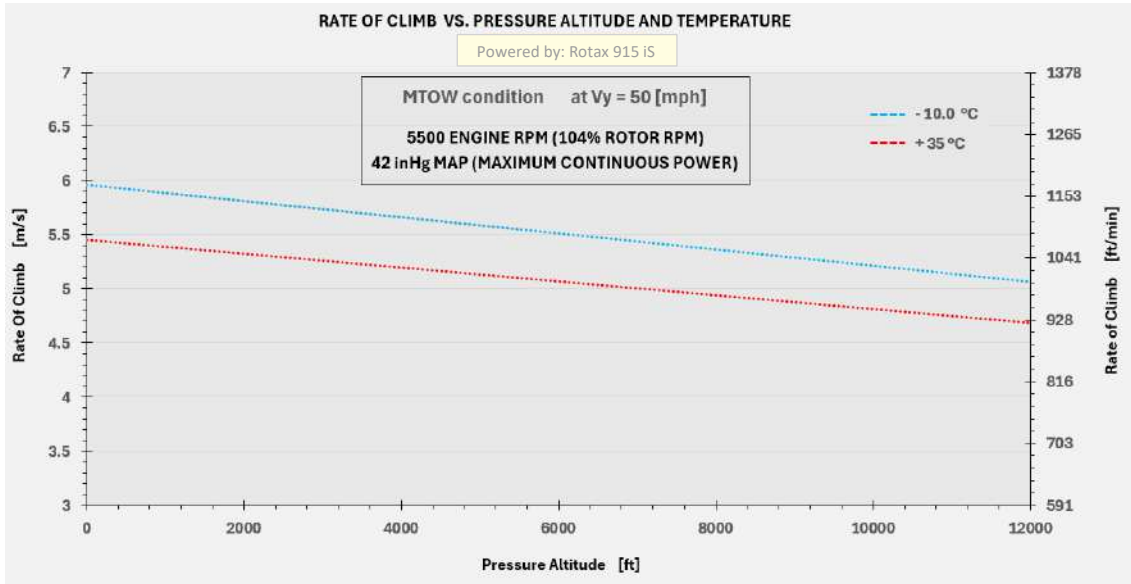

Rate of climb vs. Pressure altitude and temperature at **MinTOW** condition:

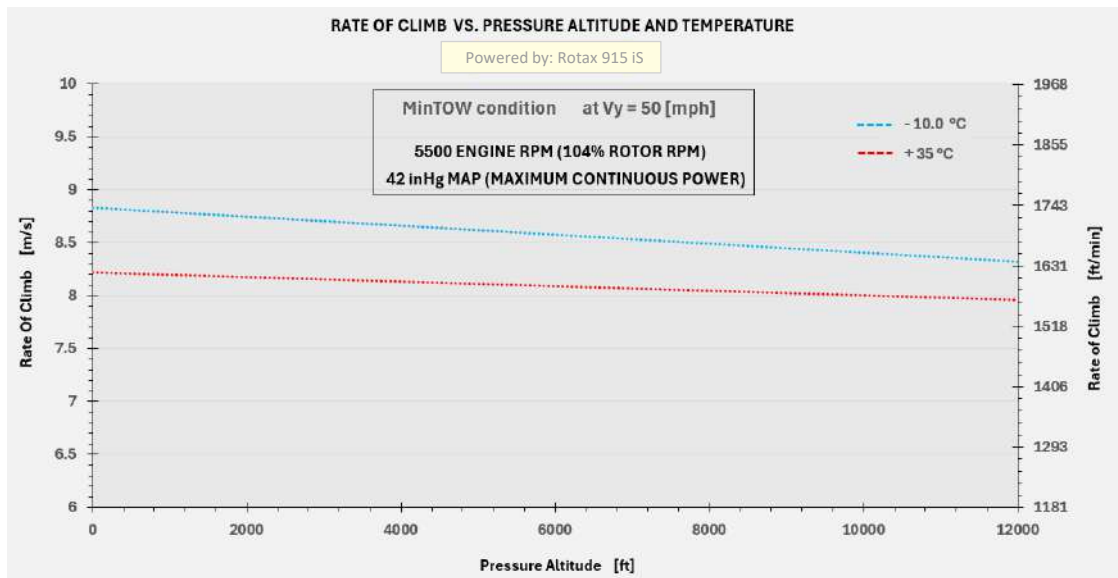

5.9 ENGINE PERFORMANCE

**Rotax 915 iS**

From Rotax data:

**Engine speed**

Parameter	Min.	Max.
Engine speed at idle	1800 rpm	–
Engine speed	–	5800 rpm (max. 5 minutes)

**Performance**

The engine performance is approximately proportional to the airflow value and can be calculated as follows:

Observed Power [kW]  $\sim -6.3264 + 0.0169 \cdot \text{Airflow [g/min]}$

Parameter	Min.	Max.
Take-off Performance (engine speed: 5800 rpm)	–	104 kW
Continuous Performance (engine speed: 5500 rpm)	–	99 kW (without governor)
Critical Altitude (MAT: max. 50 °C (120 °F))		15000 ft

**NOTE**

*The max. Continuous performance is available up to the critical altitude.*

---

**CONTENTS SECTION 6**

**6 SECTION 6 – WEIGHT AND BALANCE ..... 124**

6.1 INTRODUCTION ..... 124

6.2 CENTER OF GRAVITY (CG) LIMITS ..... 125

6.3 HELICOPTER WEIGHING PROCEDURE ..... 126

**6.3.1 AIRCRAFT PREPARATION ..... 126**

**6.3.2 WEIGHING AND BALANCE FORMS ..... 127**

**6.3.3 CORRECTION WEIGHING ..... 128**

**6.3.4 BASIC MASS RECORD FORM ..... 129**

**6.3.5 LONGITUDINAL CG VERIFICATION FORM ..... 130**

**6.3.6 LATERAL CG VERIFICATION FORM ..... 131**

## 6 SECTION 6 – WEIGHT AND BALANCE

### 6.1 INTRODUCTION

The helicopter must be flown only within weight and balance limits specified in Section 2. Loadings outside these limits can result in insufficient control travel for safe operation.

The center of gravity may be adjusted using the under-seat baggage compartment for balancing purposes (any appropriate item of mass that complies with the limits specified in Section 2). Recalculate weight and balance after adding the mass.

Each helicopter is supplied with weight and C.G. indication as measured after construction. These data are reported on the “Helicopter Weighing Record Form”.

It's Pilot's responsibility to make sure that any variation of the helicopter configuration is properly updated and recorded on the “Basic Mass Record Form”.

To calculate the C.G. position use the “Longitudinal C.G. Verification Form” and the “Lateral C.G. Verification Form” and compare it with balance limits charts.

### **CAUTION**

Always determine safe loading with minimum fuel as well as with take-off fuel.

It is not allowed to fly if balance limits cannot be respected.

6.2 CENTER OF GRAVITY (CG) LIMITS

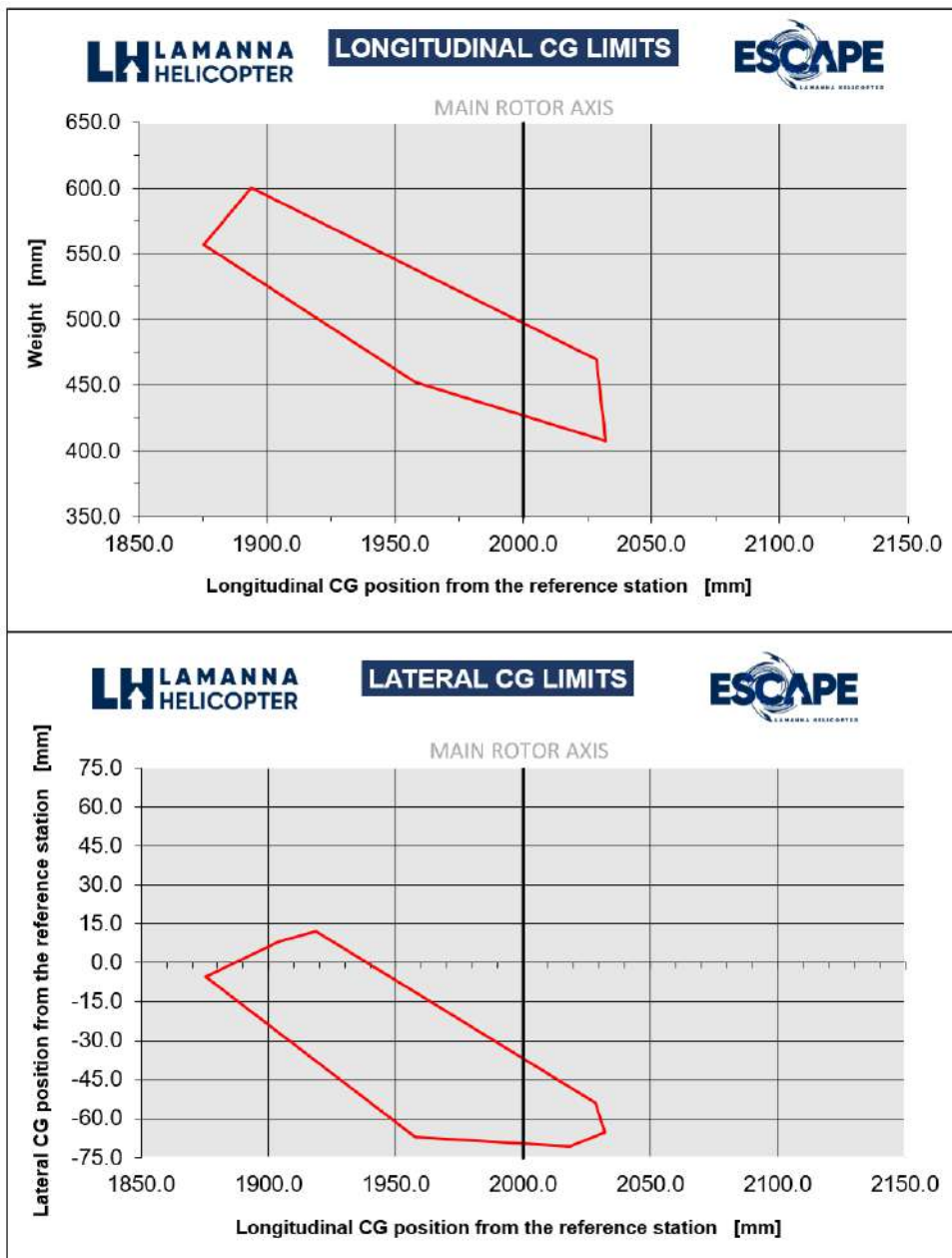
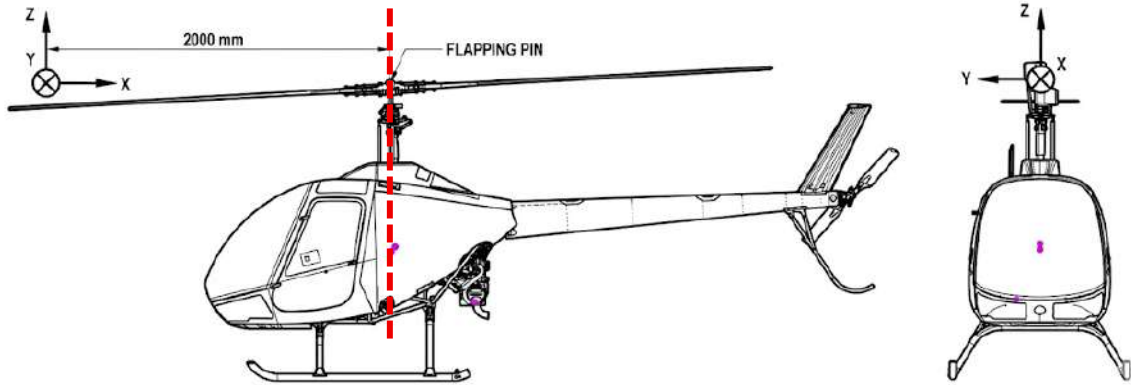

Procedure for Evaluating Take-Off CG (Center of Gravity) in Section 6: Weight and Balance

## 6.3 HELICOPTER WEIGHING PROCEDURE

### 6.3.1 AIRCRAFT PREPARATION

This procedure aims to determine the Empty Weight (EW) and the corresponding Center of Gravity (CG).

#### 1) Fluid and Load Preparation (EW Condition):

- Completely drain all usable fuel.
- Verify and ensure that the engine and transmission oil levels are at the specified operating values.
- Confirm that all permanent equipment's (per the checklist) are installed, and ensure the aircraft is clean and free of unnecessary objects (e.g., maps, tools).
- Complete the checklist detailing all installed on-board equipment's.

#### 2) Positioning and Leveling:

- Lift the helicopter and position the three load cells (200 kg capacity) underneath the specified support points (A, B, C) of the landing skid. (Represented on the next page)
- Lower the helicopter until it rests entirely on the scales, ensuring it is in perfect equilibrium before releasing the temporary support.

○ Level the helicopter laterally and longitudinally by adjusting the supports, using a level placed on the STATIC MAST to ensure 0° alignment (corresponding to the Zero Station 2000 mm forward of the Mast axis).

- Use appropriate shims or spacers under the helicopter to achieve perfect transmission leveling and record the weight of these spacers as "Tare" on the weighing form.

#### 3) Recording and Final Calculation:

- Record the mass readings from the load cells onto the official weighing form.
- Estimate the Empty Helicopter Center of Gravity  $X_{CG-EW}$ ,  $Y_{CG-EW}$  using the proposed formula.

6.3.2 WEIGHING AND BALANCE FORMS

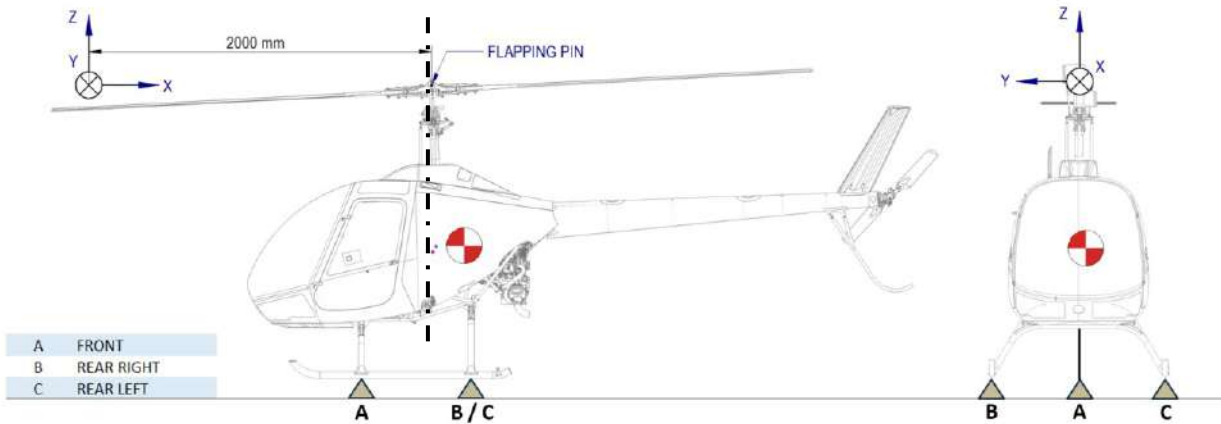

HELICOPTER WEIGHING RECORD FORM			
DATE:		HELICOPTER S/N:	
PERFORMED:		PLACE:	
SCALE POSITION	SCALE READING [kg]	TARE [KG]	NET MASS [kg]
FRONT (A)			
REAR RIGHT (B)			
REAR LEFT (C)			
TOTAL AS WEIGHED (A+B+C)			
$X_{CG} := \frac{1.247 \cdot (A) + 2.216 (B+C)}{A+B+C}$		=	[m]
$Y_{CG} := \frac{0.759 \cdot (B) - 0.759 (C)}{A+B+C}$		=	[m]
<b>ESCAPE</b>			

6.3.3 CORRECTION WEIGHING

<u><b>MASS AND BASIC MOMENT</b></u>			
HELICOPTER S/N: _____ DATE: _____			
PERFORMED BY: _____ PLACE _____			
ITEM	MASS (Kg)	ARM (mm)	MOMENT (Kg x mm)
Total as weighed			
To subtract (1)			
To add (2)			
TOTAL			
(1) Subtract useful fuel weight (if weighed with the helicopter). (2) Add optional equipment weight (if provided) and not weighed with the helicopter.			
			<b>ESCAPE</b>



6.3.5 LONGITUDINAL CG VERIFICATION FORM

<b><u>LONGITUDINAL CENTER OF GRAVITY VERIFICATION FORM</u></b>					HELICOPTER S/N:
DATE:		PERFORMED:			
BY:		PLACE:			
REF.	DENOMINATION	MASS [kg]	ARM [mm]	MOMENT [kg x mm]	C.G. TOT. MOMENT TOT. MASS
1	Basic mass (1)				X
2	Pilot		1449.5		
3	Co-pilot		1449.5		
4	Pilot's baggage		1449.5		
5	Co-pilot's baggage		1449.5		
6	Take-off fuel		2004.4		
7	Ballast		703.3		
8	Doors (only for flight without doors)	-2.8	1416.7	-3966.76	
9					
10					
11	<b>Take-off conditions (2)</b>		X		(3)
12	Used fuel (estimated)		X		X
13	<b>Estimated landing conditions</b>		X		(3)

(1) See resulting basic mass on basic mass record form.  
(2) Total take-off weight should not exceed limits indicated in Section 2 Weight limits 2.6.1.  
(3) Compare obtained values with Center of gravity (C.G.) limits. (tab 2.7)

**ESCAPE**

6.3.6 LATERAL CG VERIFICATION FORM

<u>LATERAL CENTER OF GRAVITY VERIFICATION FORM</u>					HELICOPTER S/N:
DATE:		PERFORMED:			
BY:		PLACE:			
REF.	DENOMINATION	MASS [kg]	ARM [mm]	MOMENT [kg x mm]	C.G. TOT. MOMENT TOT. MASS
1	Basic mass (1)				X
2	Pilot		-294.3		
3	Co-pilot		294.3		
4	Pilot's baggage		-294.3		
5	Co-pilot's baggage		294.3		
6	Take-off fuel		19.1		
7	Ballast		362.7		
8					
9					
10					
11	<b>Take-off conditions (2)</b>		X		(3)
12	Used fuel (estimated)		X		X
13	<b>Estimated landing conditions</b>		X		(3)

(1) See resulting basic mass on basic mass record form.  
 (2) Total take-off weight should not exceed limits indicated in Section 2 Weight limits 2.6.1.  
 (3) Compare obtained values with Center of gravity (C.G.) limits. (tab 2.7)

**ESCAPE**

**CONTEST SECTION 7**

**7 SECTION 7 – USE AND MAINTENANCE ..... 133**

7.1 INTRODUCTION ..... 133

7.2 REQUIRED DOCUMENTS ..... 134

7.3 ROUTINE INSPECTIONS ..... 135

7.4 REMOVABLE FLIGHT CONTROLS ..... 136

7.5 GROUND HANDLING ..... 137

7.6 ROAD TRANSPORT AND TRAILING ..... 140

## 7 SECTION 7 – USE AND MAINTENANCE

### 7.1 INTRODUCTION

This section outlines procedures recommended by Lamanna Helicopter s.r.l. (hereafter LH) for the use and maintenance of the ESCAPE helicopter.

Every owner should stay in close contact with LH or his LH dealer to obtain the latest information on the ESCAPE.

The owner must arrange to be registered with LH to receive bulletins, changes to this handbook, and other helpful information as it becomes available.

The official legal application of new manuals and service bulletins and other information is starting from the moment is published on LH official website.

The pilot is bound to refer to website [www.lamannahelicopter.com](http://www.lamannahelicopter.com) section S.B. (Service Bulletin) to check aircraft airworthiness is following Service Bulletins released before every flight procedure. The manuals and bulletins issued by ROTAX, subject to official validation by LH through specific Service Letters.

LH transfers maintenance responsibility to each owner and operator of the ESCAPE. This person has to be sure that all maintenance procedures are performed by qualified mechanics in compliance with every disposition released by LH.

Each limitation, procedure, safety regulation, time limit, maintenance tables in this manual has to be considered mandatory.

## 7.2 REQUIRED DOCUMENTS

The following documents must peremptorily always be in the aircraft:

- 1) Registration certificate (copy)
- 2) Payment coupon of the Insurance policy (copy)
- 3) Weight and balance data
- 4) Pilot's Check List

The following documents must peremptorily be completed and always updated

- 1) Maintenance handbook
- 2) Pilot's Operating Handbook
- 3) Helicopter logbook
- 4) Engine logbook

### 7.3 ROUTINE INSPECTIONS

Routine inspections are those that the user can perform independently after a short training course delivered by LH or an authorised Dealer's:

- 1) Daily Inspection: as specified in section 3.1.
- 2) 50 hours inspection: as specified in the maintenance program (inside the maintenance manual), it is recommended to perform fuel filters (gascolator filter) and air filter cleaning.

#### **NOTE**

The pilot is responsible for ensuring that all inspections are carried out in accordance with the approved maintenance program.

## 7.4 REMOVABLE FLIGHT CONTROLS

- **CYCLIC**

Right seat cyclic controls may be removed and installed by maintenance personnel or pilots, as follows:

To remove cyclic control lever, unscrew and remove the fixing bolt, then pull outward the right handle while supporting the control bar, then disconnect the quick-release pin. To install use reverse procedure.

### **CAUTION**

Operations must be carried out with the engine off and key disengaged. After removing cyclic grip lever, place plastic cap provided on the exposed tube to prevent possible damage or injuries.



- **PEDALS**

To remove tail rotor pedals, push the spring clamp at the bottom of pedals, pull the pedals upwards while twisting them. To install, insert the pedals in the outlets, turn them until you reach the marked height and until the hole is aligned, and then check that spring clamp is in the right position. The pedals are not interchangeable; please reposition them correctly on the right and left sides, respectively.



## 7.5 GROUND HANDLING

Procedure description:

For ground handling, the helicopter must be equipped with special ground handling wheels. Follow the indicated sequence to avoid structural damage or overturning.

- **Positioning:** Attach the wheels to the appropriate attachments located on the skid tubes, making sure that the locking pins are fully inserted and secured.

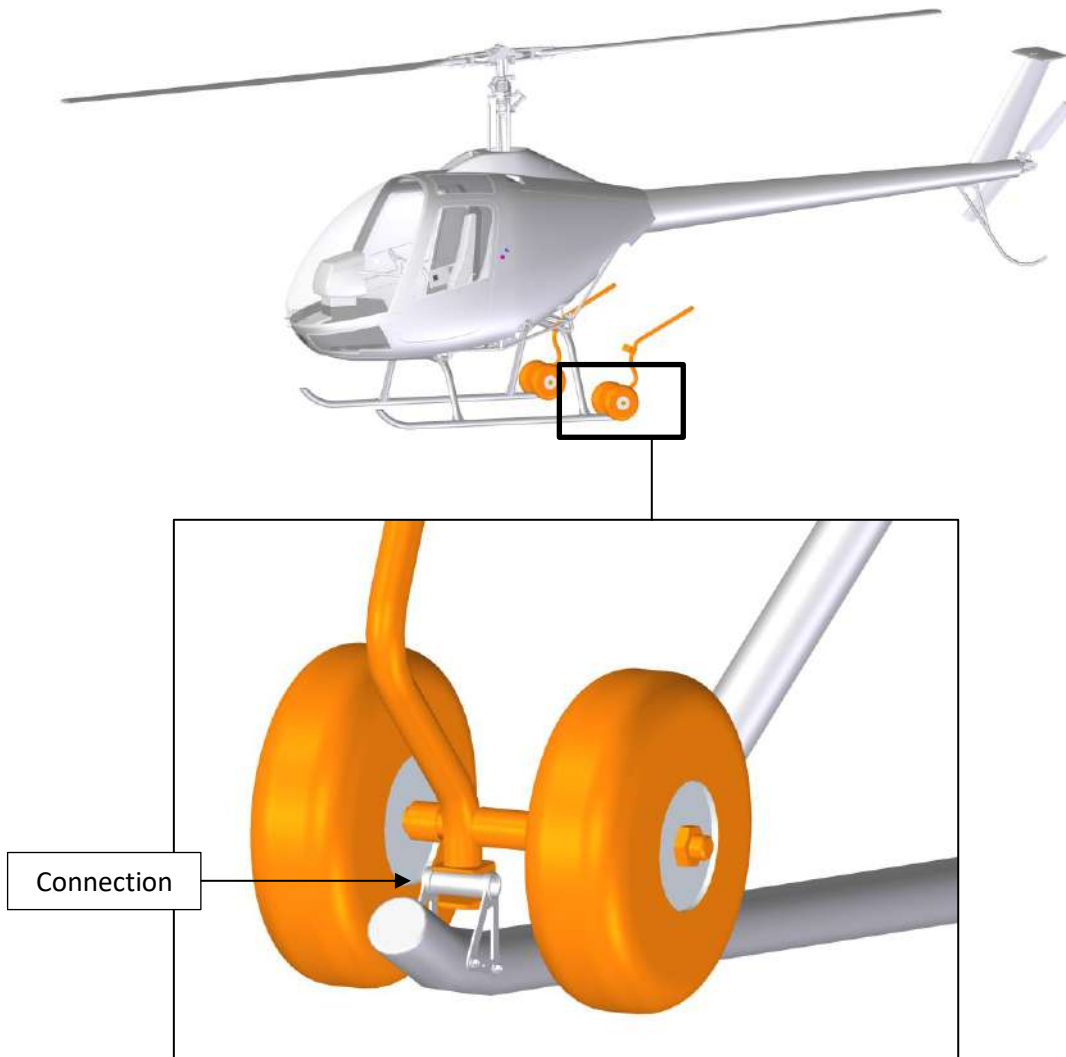

- **Hookup:** Use the lever system to lift the skids off the ground. Make sure the helicopter is in stable balance before starting the movement.

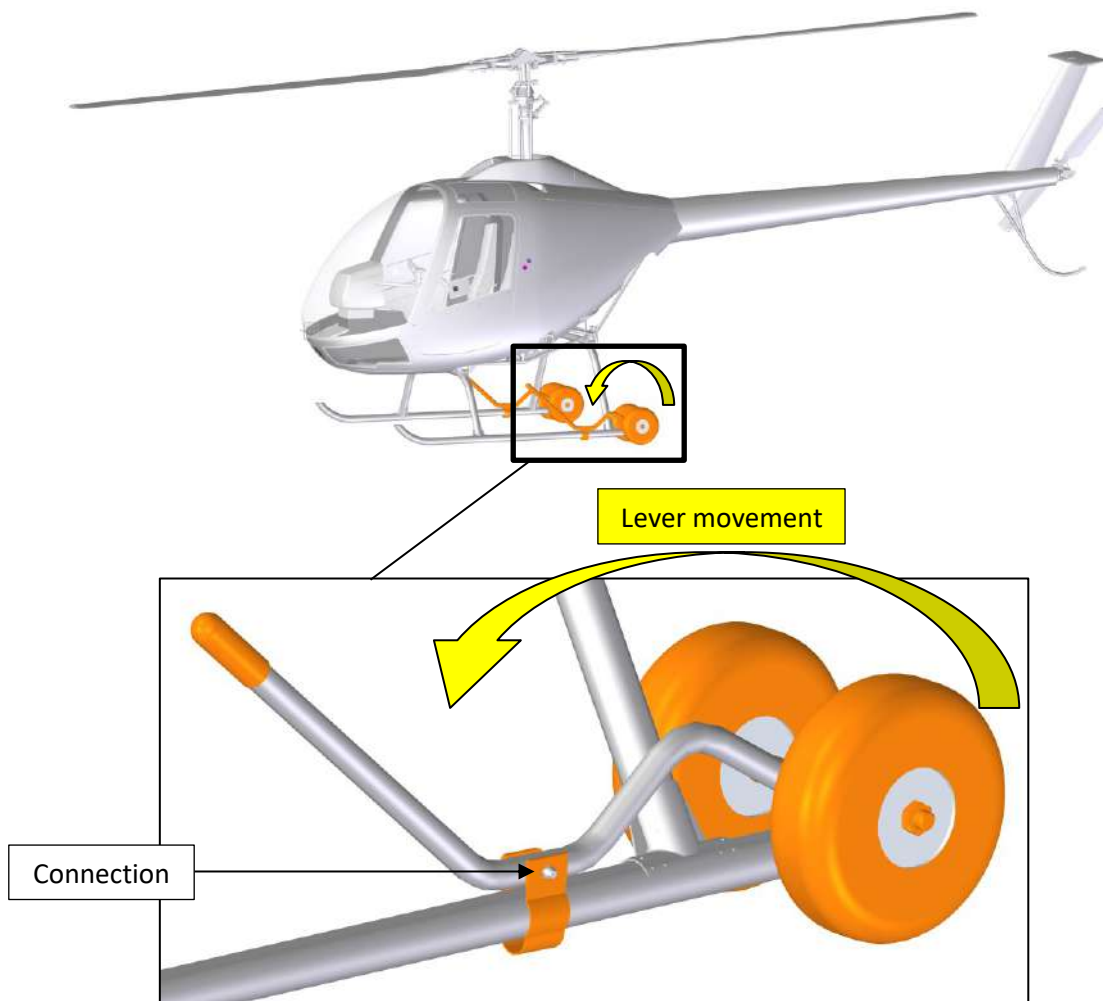

- **Maneuver:** For manual movement, tilt the helicopter and push the aircraft only by acting on the designated push points.



Fixing points on which to apply force:

- Main: Tail rotor gearbox.
- Secondary: Frame.

### **CAUTION**

Never apply pressure to the rotor blades, tail rotor or control surfaces to avoid structural deformations.

## 7.6 ROAD TRANSPORT AND TRAILING

Specific procedures for securing, anchoring, and transporting the helicopter on a vehicle-towed trailer must be performed in strict accordance with the manufacturer's specifications.

For safety and right procedures, please contact Lamanna Helicopter srl directly.

## 7.7 HOISTING PROCEDURES

This procedure describes how to lift the helicopter for maintenance operations:

### Lifting Eye Installation

- **Inspection:** Verify that the threads of the Lifting Eye and the mast threads are clean and free of debris.
- **Installation:** Manually screw the hook until it is fully seated and ensure the eye bolt is securely fastened before attaching any lifting equipment.



### Attachment and Lifting

- **Attachment:** Use only the lifting hook provided by Lamanna Helicopter.
- **Lifting:** Before proceeding with a full lift, slightly raise the aircraft to verify that it is correctly balanced and proceed with the lifting operation.



### CAUTION

DO NOT stand under the helicopter during lifting operations or while it is suspended.